



infiniti

SIT AROUND THE WORLD

LONDON

SYDNEY

NEW YORK

MOSCOW

ROME

TOKYO

SIT AROUND THE WORLD

TRAVELLING WITH IMAGINATION AND HAVING FUN IS PART OF OUR NATURE: AN INFINITI SEAT IS A TRIP WITHOUT HAVING TO MOVE, AMONG COLOURS, SHAPES, AND MATERIALS THAT EVOKE PLACES, SCENTS AND SOUNDS OF DIFFERENT AND AMAZING WORLDS.

TRAVEL WITHOUT MOVING

OVER THE PAST FEW YEARS WE HAVE GROWN. WE HAVE BECOME OLDER AND MATURE. WE HAVE STARTED LOOKING BACK AT OUR HISTORY MADE OF PASSION FOR BEAUTIFUL THINGS FROM ALL OVER THE WORLD. WE HAVE REALISED WE ENJOY TELLING STORIES AND LISTENING TO THEM, WITH PURE EYES AND A CLEAN HEART, ALWAYS WATCHING THINGS AS IF IT WAS THE FIRST TIME WITH CURIOSITY AND ENTHUSIASM, APPRECIATING ALL OF THEM. WE SAT AROUND THE WORLD TO EXPORT AN ALL-ITALIAN KNOW-HOW, FEATURING A HIGHLY-PERSONAL COSMOPOLITAN VIEW. THIS IS INFINITI TODAY.



INDEX



CHAIRS

- 12 SETTESUSETTE
- 20 TONDINA
- 34 BI
- 44 NEXT
- 52 NOW
- 62 GLOSSY
- 68 PORTA VENEZIA
- 78 SEAME
- 88 EMMA
- 94 PENELOPE
- 100 PURE LOOP BINUANCE
- 108 PURE LOOP
- 120 PURE LOOP MINI
- 130 LOOP
- 148 FIORELLINA
- 160 DROP
- 168 MARGOT
- 176 G-CHAIR
- 184 CALLITA
- 192 COOKIE
- 202 WEB
- 208 GIULITTA
- 218 ARKUA
- 224 HUG
- 234 CHARLOTTE
- 240 PIN UP
- 246 BEETLE
- 252 BRONCIO
- 256 ZED STOOL
- 264 PICAPAU STOOL
- 274 BOBO STOOL

BOOKCASES

282 ARIGATÒ

TABLES

- 286 DUEPERDUE
- 290 NEXT TABLE
- 294 MAT
- 298 TRENDSETTER
- 302 POINTBREAK
- 306 ELEPHAS
- 310 EMMA TABLE
- 314 PORTA VENEZIA TABLE
- 322 LOOP TABLE
- 326 LINE
- 330 BOMBÈ
- 334 DROP TABLE
- 338 3-POD
- 342 PLANO

SIT AROUND THE WORLD

- 8 AMSTERDAM
- 18 VARANASI
- 30 CAPE TOWN
- 158 SIDNEY
- 182 TOKYO
- 216 LISBON
- 262 SAN FRANCISCO
- 272 MOSCOW

FINISHES

- 346 FINISHES

CHAIRS

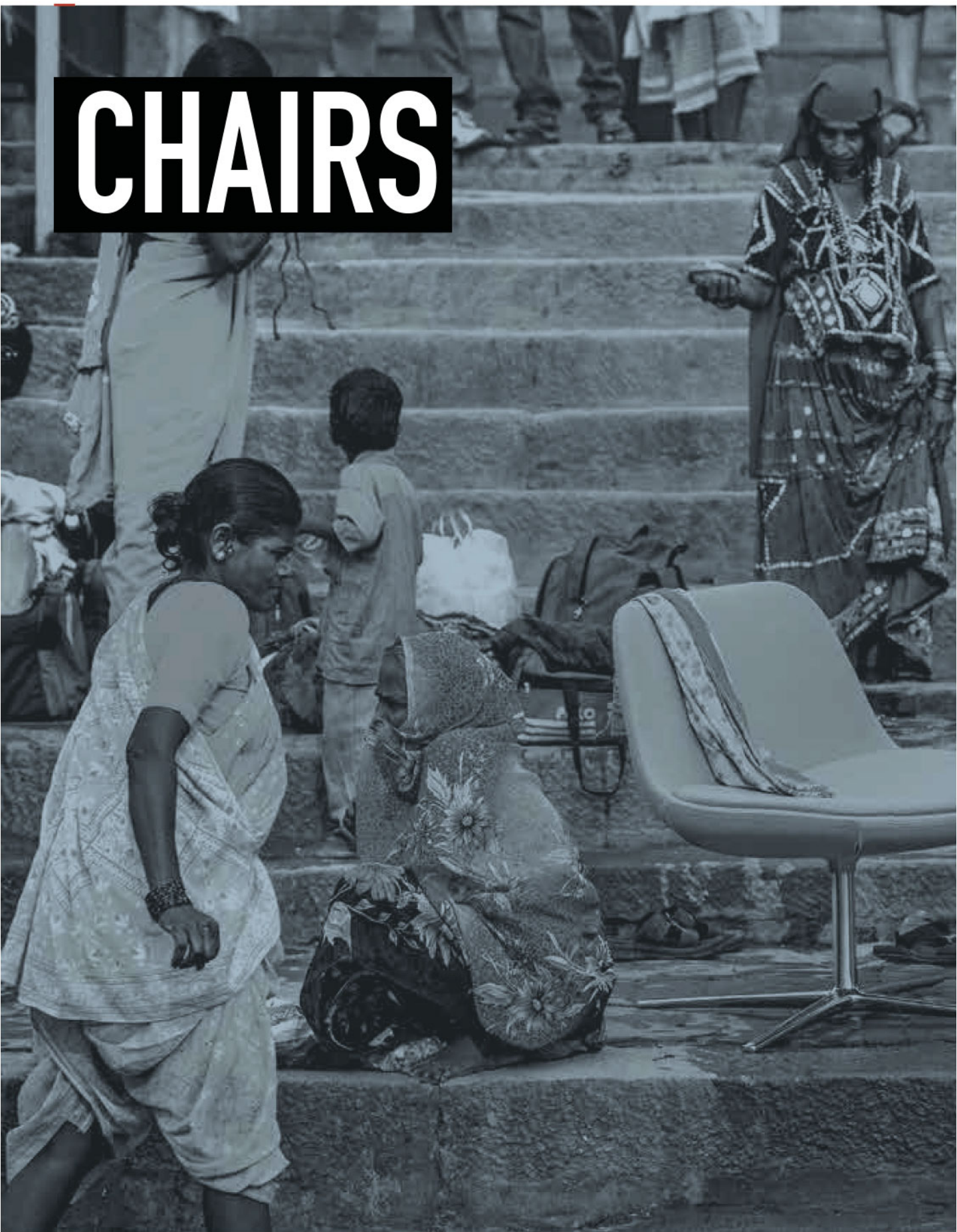



AMSTERDAM

—

A SERIES OF CANALS AND NARROW LANES DIVIDE THE HISTORICAL STREETS AND RESIDENCES OF THIS WONDERFUL CITY WHICH WAS FOUNDED AS A FISHING VILLAGE BUT FLOURISHED UNDER COLONIALISM. AMSTERDAM HAS ONE OF THE LARGEST RENAISSANCE CENTRES IN EUROPE WHERE THERE HAS ALWAYS BEEN AN ATMOSPHERE OF ART AND FREEDOM.



GPS

Latitude N 52° 22' 12"
Longitude E 4° 53' 42"











SETTESUSETTE

Designers Alberto Brogliato and Federico Traverso have put their signatures on this new family of products, starting with the four-leg basic version: the continuity of the shapes between the two materials, which can be fully appreciated on the back of the seat, is the true strength of its design.



SETTESUSETTE

DESIGN:
BROGLIATOTRAVERSO

—
STACKABLE CHAIR WITH SOLID BEECH WOOD FRAME, AND POLYPROPYLENE SEAT AND BACKREST. THE SEAT CAN BE UPHOLSTERED IN LEATHER, ECO-LEATHER OR FABRIC.

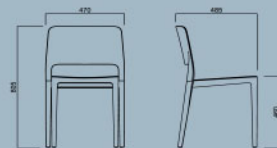

—
WOOD AND PLASTIC PERFECTLY BLEND TO GIVE LIFE TO AN ELEGANT GRACEFUL COMPOSITION. WITH ITS SLEEK LINEAR DESIGN, SETTESUSETTE IS SUITABLE TO BE USED BOTH IN RESIDENTIAL AND CONTRACT SPACES. THE REFINED COLOUR COMBINATIONS MAKE THIS CHAIR BLEND IN WELL WITH ANY VINTAGE INTERIORS.



SETTESUSETTE
CHAIR

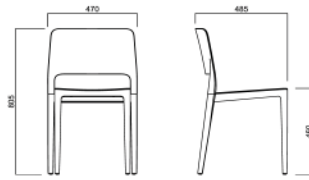

TELAIO/Frame

MASSELLO DI FAGGIO

Solid beech



MAFGV
Faggio naturale
Natural beech

MAF104
Faggio verniciato nero
Black painted beech

SEDILE E SCHIENALE
Seat and backrest

POLIPROPILENE

Polypropylene



PP20
Bianco
White

PP31
Nero carbone
Coal black

PP7608C
Marsala
Marsala

PP557C
Verde acqua
Light teal

PP421C
Grigio mandorla
Almond

PP27
Curry
Curry

TAPPEZZERIA

Upholstery

Canvas Kvadrat
Cava 3 Kvadrat
Divina 3 Kvadrat

Divina Melange 2
Kvadrat
Outback Kvadrat

Field Kvadrat
Umami Kvadrat

Flash No-shrink
Byte

PELLE FIORE

Full-grain leather

ECOPELLE

Eco leather

VARANASI

—
A MAGICAL CITY THAT
EVOKES ANCIENT RITUALS
STRETCHING INTO INFINITY.
THE COLOURS AND SCENTS
OF A FASCINATING, FAR OFF
LAND, FULL OF SPIRITUALITY
AND PRIMITIVE PURITY.



GPS

Latitude N 28° 19' 3"
Longitude E 82° 58' 26"







TONDINA

The project by Favaretto & Partners is inspired by the rigour of Nordic design. The family, initially created in the chair and lounge versions, has grown to include the stool and the Pop version, with coloured plastics and frame.



TONDINA

DESIGN:
FAVARETTO&PARTNERS

—
CHAIR WITH POLYPROPYLENE
SEAT AND BACKREST, AND FOUR-
LEG STEEL FRAME WITH OR
WITHOUT ARMS.

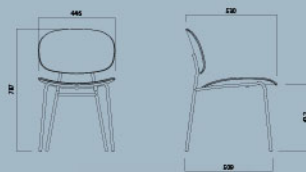
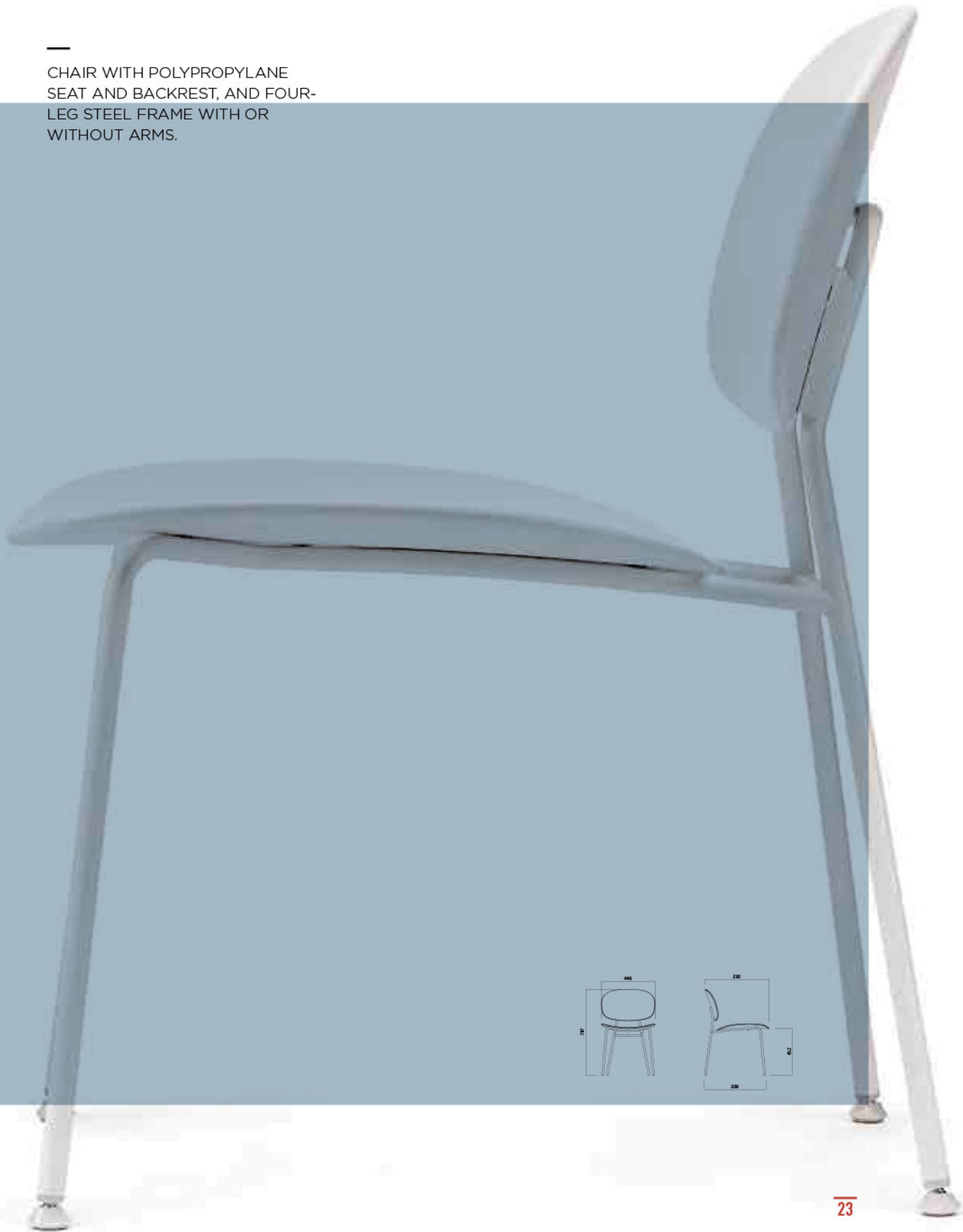

—
A SLEEK DELICATE SILHOUETTE AND A
STRONG VERSATILITY ARE THE DISTIN-
GUISHING FEATURES OF THIS CHAIR
THAT SEAMLESSLY BLENDS IN WITH THE
MOST DIVERSE INTERIORS.





TONDINA
LOUNGE



TONDINA POP
4 LEGS

TONDINA POP 4 LEGS

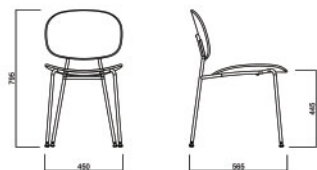
RIVESTIMENTO
UpholsteryIMPILABILITÀ
StackabilityESTERNO
Outdoor

TONDINA POP 4 LEGS WITH ARMS



TONDINA 4 LEGS

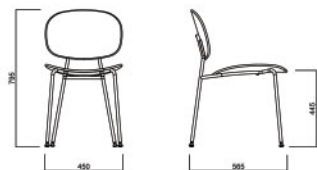

TONDINA 4 LEGS WITH ARMS



TELAIO/Frame

TELAIO IN ACCIAIO

Steel frame

AC01
Cromato
Cromium-platedAC30
Verniciato bianco opaco
White matt paintedAC31
Verniciato nero opaco
Black matt paintedAC12
Cromato nero
Black chromeAC13
Cromato rame
*Copper chromed*SEDILE E SCHIENALE/
Seat and backrest

POLIPROPILENE

PP34
Pesca
PeachPP31
Nero carbone
Coal blackPP7608C
Marsala
MarsalaPP557C
Verde acqua
Light tealPP421C
Grigio mandorla
Almond greyPP480C
Cipria
CipriaPP20
Bianco
White

TONDINA KITCHEN STOOL

RIVESTIMENTO
Upholstery

IMPILABILITÀ
Stackability

ESTERNO
Outdoor



TONDINA BAR STOOL



TONDINA LOUNGE

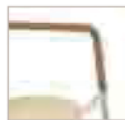

*Optional su richiesta:
copribraacciolo in cuoio.
Optional on request:
armrest cover in leather.*

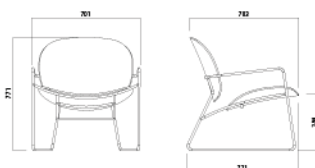

**SEDILE E SCHIENALE/
Seat and backrest**

LEGNO MULTISTRATO IN 3D

3D Plywood



LR01
Rovere sbiancato
Whitened oak



LR02
Rovere wengè
Wenge-stain oak



LR03
Rovere naturale
Natural oak



LR04
Rovere verniciato ocre
Ochre painted oak



LR05
Rovere verniciato bordeaux
Bordeaux painted oak



LR06
Rovere verniciato antracite
Anthracite painted oak



LR07
Rovere verniciato verde
Green painted oak



LR08
Rovere verniciato nero
Black painted oak

TAPPEZZERIA

Upholstery

Canvas Kvadrat
Cava 3 Kvadrat
Divina 3 Kvadrat

Divina Melange 2
Kvadrat
Outback Kvadrat

Field Kvadrat
Umami Kvadrat

Flash No-shrink
Byte

PELLE FIORE

Full-grain leather

ECOPELLE

Eco leather





CAPE TOWN

—

THE EXCELLENT CLIMATE AND SPECTACULAR POSITION, OVERLOOKING THE OCEAN AND AT THE FOOT OF TABLE MOUNTAIN, MAKE THIS CITY HEAVEN ON EARTH. THE WONDERFUL SURROUNDING BEACHES OFFER EVERY KIND OF WATER SPORT IMAGINABLE, OR YOU CAN SIMPLY LAZE ON THE BEACH AND SOAK UP THE SUN.



GPS

Latitude N 33° 55' 29"
Longitude E 18° 25' 26"



CHAIRS

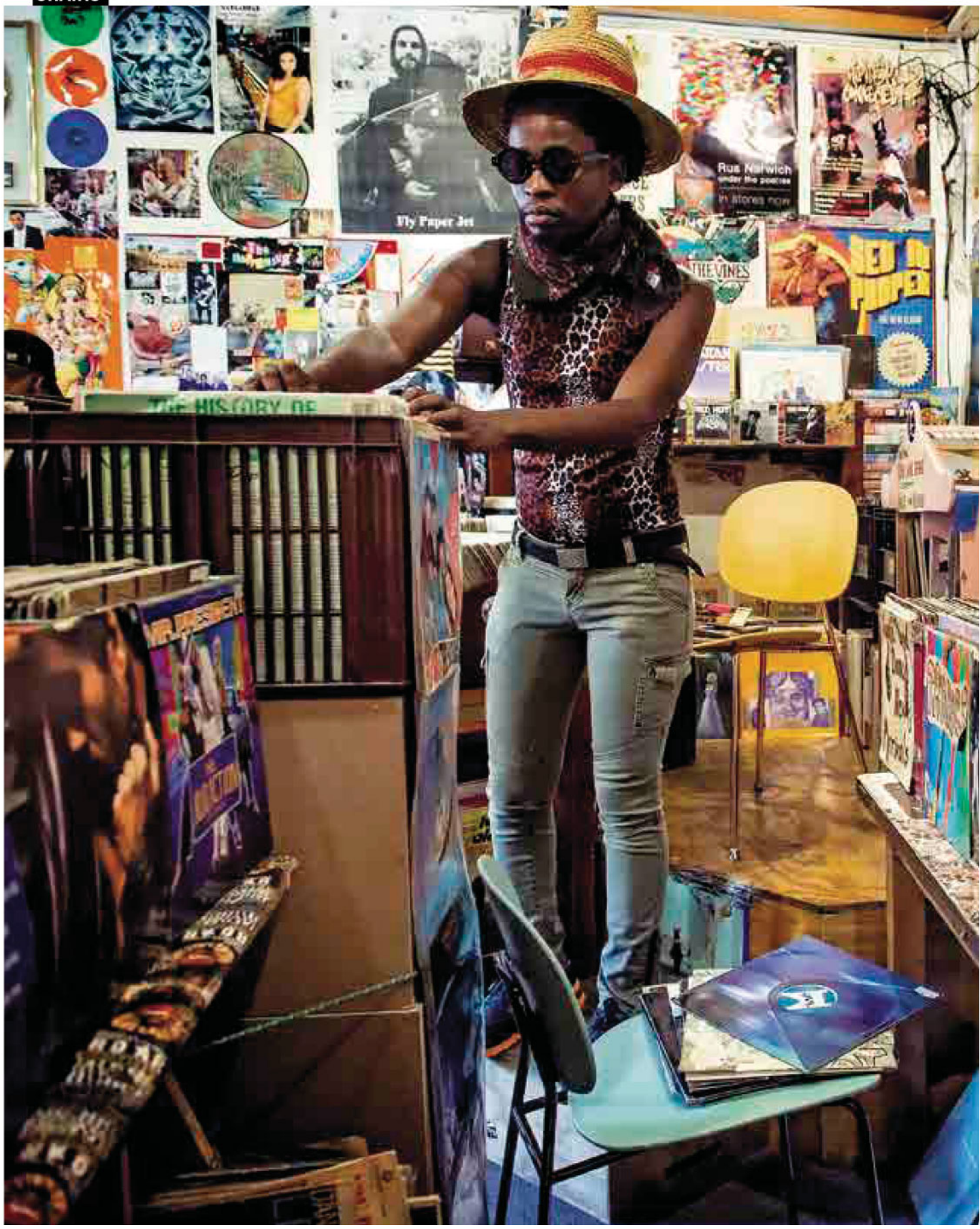







BI

With this project Marc Sadler wanted to develop a "platform" product where he could introduce an element of discontinuity, making it possible to cover different commercial areas. The comfortable, high-performance base has been paired with a light polycarbonate or wood backrest, then in the "full back" version with a more enveloping one in polyurethane. Bi 20s is the latest striking creation to become part of the family.



—





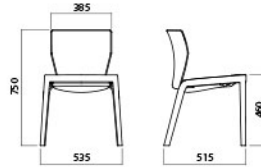

BI

RIVESTIMENTO
UpholsteryIMPILABILITÀ
StackabilityESTERNO
Outdoor

BI 3D WOOD

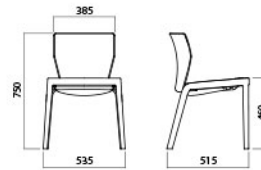

TELAIO/Frame

POLIPROPILENE

Polypropylene

PP20
Bianco
WhitePP11
Antracite
AnthracitePP22
Tabacco
TobaccoPP01
Nero
Black

SCHIENALE/Backrest

POLICARBONATO
TRASPARENTETransparent
polycarbonatePC103
Ghiaccio
IcePC104
Fumé
Smoke-greyPC123
Vinaccia
*Burgundy*POLICARBONATO
COPRENTESolid colour
polycarbonatePC131
Bianco
WhitePC102
Nero
BlackPC126
Antracite
AnthracitePC124
Giallo dalia
Dalia yellowPC125
Sabbia
SandPC128
Tabacco
Tobacco

SCHIENALE/Backrest

LEGNO MULTISTRATO IN 3D

3D Plywood

LR01
Rovere sbiancato
Whitened oakLR02
Rovere wengè
Wenge-stain oakLR03
Rovere naturale
Natural oakLR04
Rovere verniciato ocra
Ochre painted oakLR05
Rovere verniciato bordeaux
Bordeaux painted oakLR06
Rovere verniciato antracite
Anthracite painted oakLR07
Rovere verniciato verde
Green painted oakLR08
Rovere verniciato nero
Black painted oak

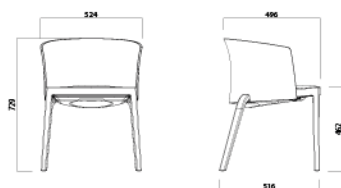

BI 20s

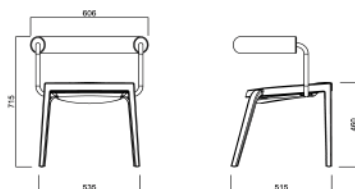

SCHIENALE BI FULL E BI 20's/
BI Full e BI 20's Backrest

POLIURETANO
COLORATO



Colour polyurethane

PU20
Bianco
White

PU03
Nero
Black

PU15
Grigio traffico
Traffic grey

PU14
Rosso rubino
Ruby red

PU13
Sabbia
Sand

PU17
Giallo
Yellow

SUPPORTO SCHIENALE BI 20s IN ACCIAIO



Steel backrest support

AC30
Verniciato bianco
opaco
White matt painted

AC31
Verniciato nero
opaco
Black matt painted

AC33
Verniciato sabbia
opaco
Sand matt
painted

AC11
Verniciato gofrato
antracite
Embossed
anthracite painted

AC22
Verniciato
tabacco opaco
Tobacco matt
painted

Supporto schienale in tinta con il telaio oppure cromato.
Supporto schienale in tinta con il telaio oppure cromato.

TAPPEZZERIA

Upholstery

Canvas Kvadrat
Cava 3 Kvadrat
Divina 3 Kvadrat

Divina Melange 2
Kvadrat
Outback Kvadrat

Field Kvadrat
Umami Kvadrat

Flash No-shrink
Byte

PELLE FIORE

Full-grain leather

ECOPELLE

Eco leather









NEXT

Plastic, steel, and wood: three materials in a single, extremely elegant product, winner of the Good Design Award in 2014. Its wooden legs can be painted with a natural effect or lacquered in the same colour as the shell.



NEXT

DESIGN:
ANDREAS OSTWALD

NEXT

POLYAMIDE MOULDED PERFORATED SHELL. THE BASE FEATURES SOLID BEECH WOOD LEGS AND AN ALUMINIUM SUPPORT.





NEXT
4 LEGS

—
NEXT FINDS ITS IDEAL PLACE IN MODERN AND MINIMALIST SETTINGS. THE IROKO SOLID WOOD FRAME MAKES IT A STURDY CHAIR, SUITABLE FOR OUTDOOR ENVIRONMENTS.



NEXT
4 LEGS OUTDOOR

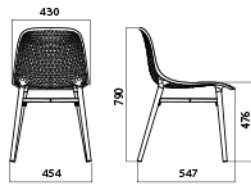

NEXT 4 LEGS OUTDOOR

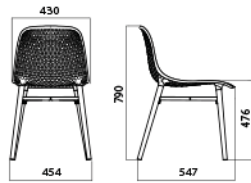

TELAIO/Frame

TELAIO MASSELLO DI FAGGIO

Solid beech frame



MAFGV
Faggio naturale
Natural beech

TELAIO MASSELLO DI IROKO

Solid Iroko wood frame
Solo per per versione da esterno
Only for external version



IRK01
Tinto nero
Black painted

TELAIO MASSELLO DI FAGGIO LACCATO

Lacquered solid beech frame

N.B. Gambe laccate nello stesso colore della scocca
N.b. Lacquered legs in the same colour as the shell



MAFLG6
Bianco
White



MAF01
Grigio siliceo
Silica grey



MAF02
Nero
Black



MAF03
Rosso
Red



MAF04
Giallo
Yellow



MAF05
Verde
Green



MAF06
Blu Capri
Capri blue

SCocca/Shell

SCocca IN POLIAMMIDE

Polyamide shell



PA101
Bianco
White



PA117
Grigio siliceo
Silica grey



PA102
Nero
Black



PA114
Rosso
Red



PA120
Giallo
Yellow



PA119
Verde
Green



PA121
Blu Capri
Capri blue

Finitura ad olio per uso esterno. Si consiglia dopo 6/8 mesi di applicare un successivo trattamento di protezione.
Oil finish for outdoor use. It is recommended to reapply a protection treatment after 6/8 months.

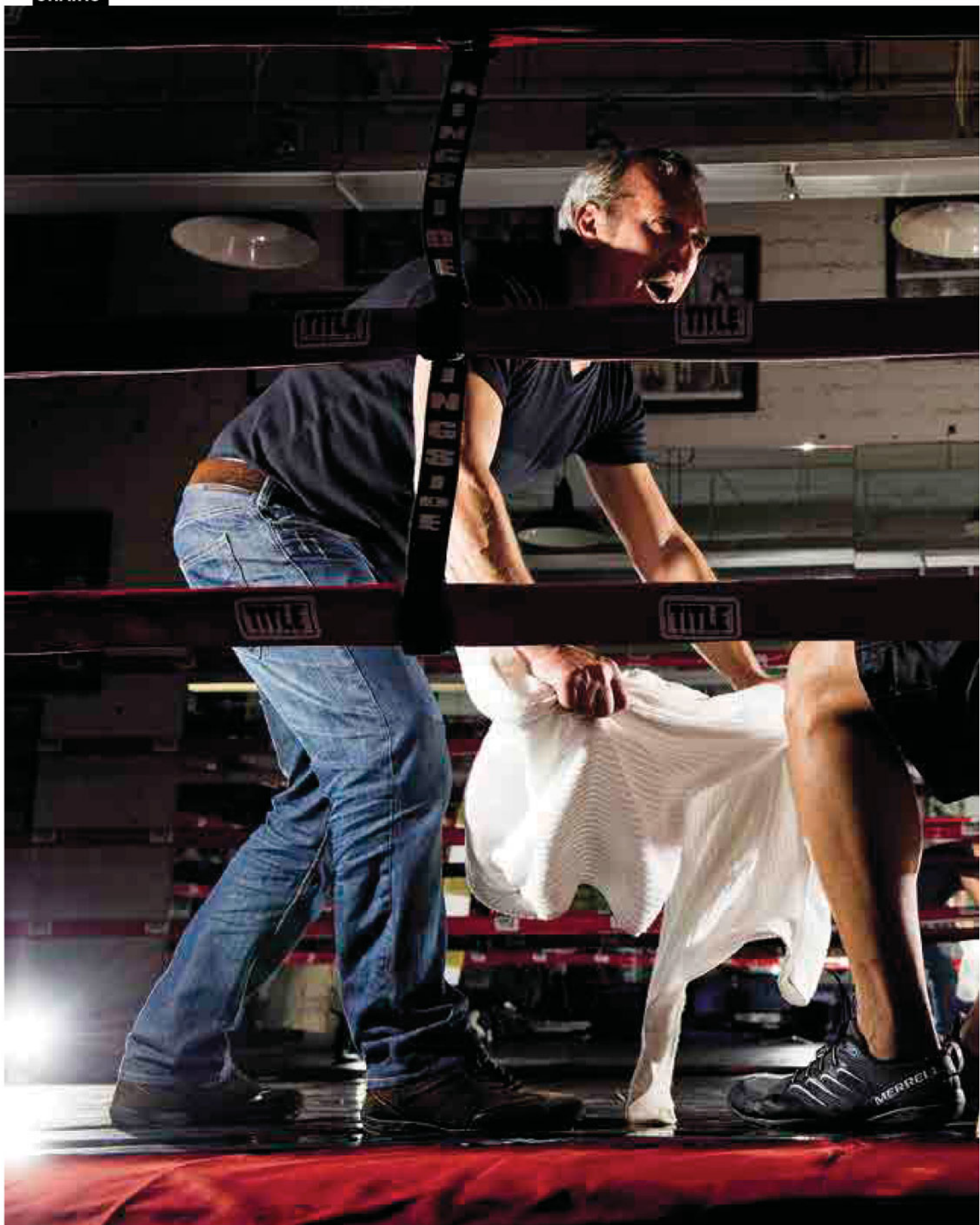

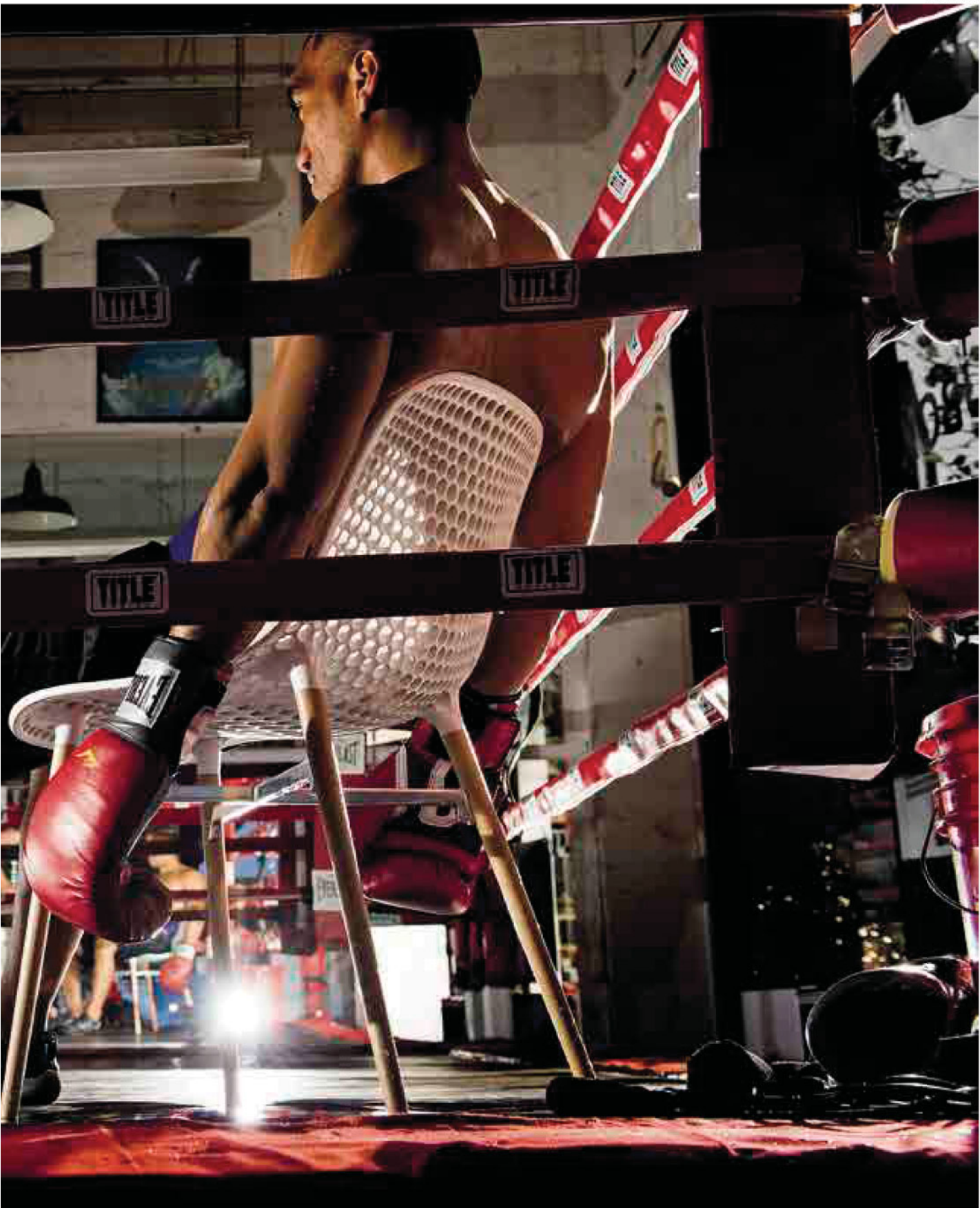





NOW

Now is a seat with countless variants that adapts perfectly to any type of contract setting. All bases are available chromium-plated and painted, and all versions can be provided with an upholstered panel.

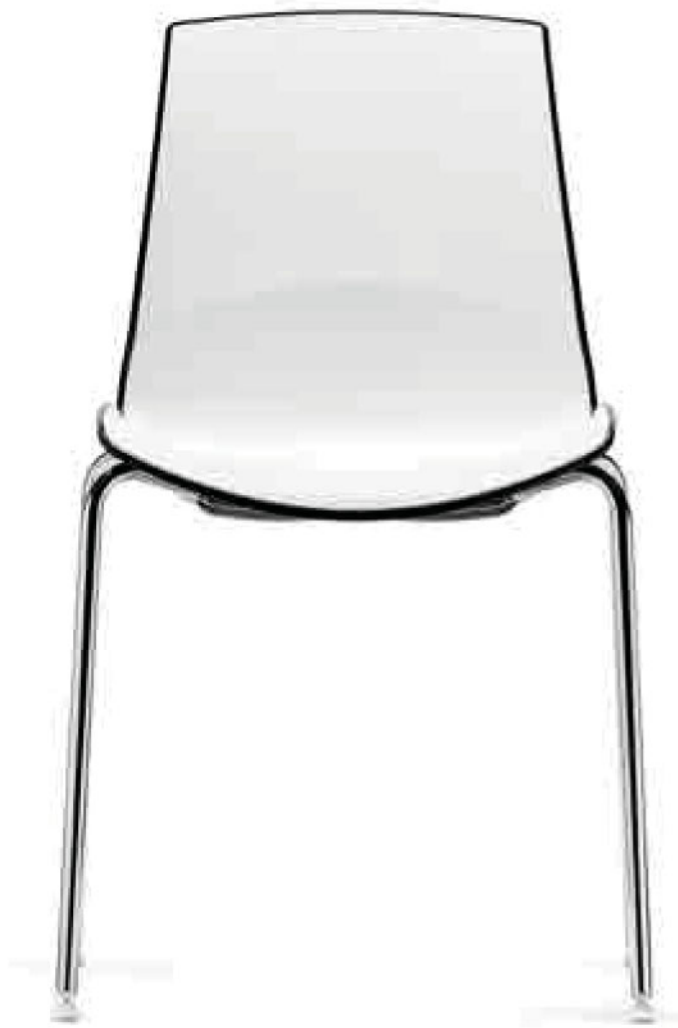

NOW

DESIGN:
SANDONÀ & SANDRIN

—
TWO-COLOUR SHELL WITH MATT
WHITE INTERNAL SIDE AND
POLISHED COLOURED EXTERNAL
SIDE (MANY DIFFERENT COLOURS
AVAILABLE). CHROMIUM-PLATED
STEEL FOUR-LEG FRAME.

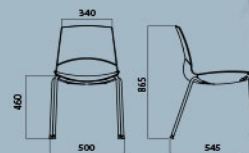

NOW 4 LEGS

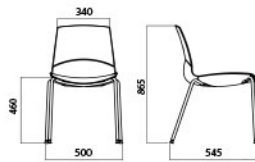
RIVESTIMENTO
UpholsteryIMPILABILITÀ
StackabilityESTERNO
Outdoor

NOW 4 LEGS WITH ARMS

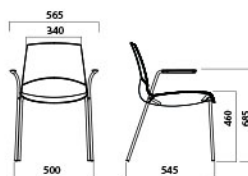

NOW 4 LEGS WITH CLOSED ARMS

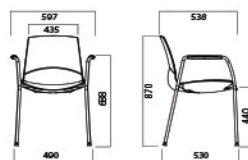

NOW SLEDGE

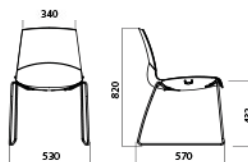

NOW SLEDGE WITH ARMS

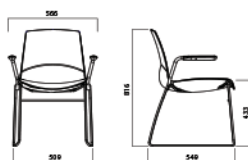

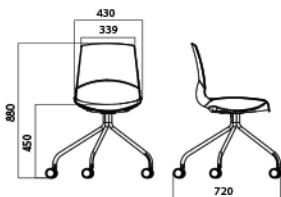

NOW SWIVEL WITH ARMS

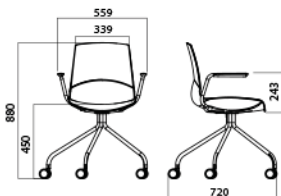

NOW SWIVEL GAS LIFT

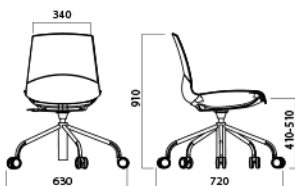

NOW SWIVEL GAS LIFT WITH ARMS

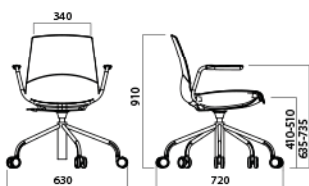

NOW 4 LEGS STOOL

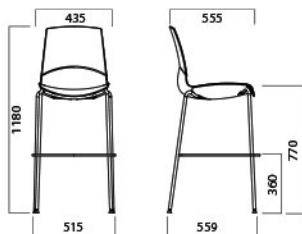
RIVESTIMENTO
UpholsteryIMPILABILITÀ
StackabilityESTERNO
Outdoor

NOW SLEDGE STOOL

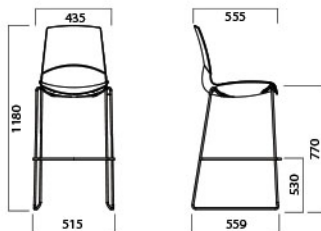

TELAIO/Frame

TELAIO IN ACCIAIO

Steel frame

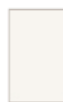

AC01
Cromato
Cromium-plated

AC30
Verniciato bianco
opaco
White matt painted

AC31
Verniciato nero
opaco
Black matt painted

AC32
Verniciato grigio
opaco
Grey matt painted

SCocca/Shell

POLIPROPILENE

Polypropylene



PP20/PP3020
Bianco/Rosso
White/Red

PP20/PP27
Bianco/Curry
White/Curry

PP20/PP6018
Bianco/Verde
tropicale
White/Tropical
green

PP20/PP514
Bianco/Sabbia
White/Sand



PP20/PP01
Bianco/Nero
White/Black

PP20/PP21
Bianco/Grigio
perla
White/Pearl grey

PP20/PP2905C
Bianco/Celeste
White/Light blue

PP20/PP20
Bianco/Bianco
White/White

TAPPEZZERIA

Upholstery

Canvas Kvadrat
Cava 3 Kvadrat
Divina 3 Kvadrat

Divina Melange 2
Kvadrat
Outback Kvadrat

Field Kvadrat
Umami Kvadrat

Flash No-shrink
Byte

PELLE FIORE

Full-grain leather

ECOPELLE

Eco leather









GLOSSY

A one-piece seat originally designed in polycarbonate (available with fabric cover) and later developed in a wooden version. All versions are available with a chromium-plated or polished painted steel frame.



GLOSSY

DESIGN:
STEFANO SANDONÀ

—
FOUR-LEG FRAME WITH A
COMFORTABLE, SINOUS SHELL
FEATURING TWO LITTLE "HEMS":
SUITABLE TO DECORATE CAFÉS
AND RESTAURANT SPACES.

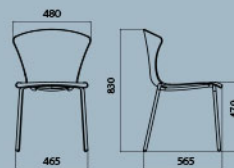



GLOSSY
CHAIR



GLOSSY
CHAIR

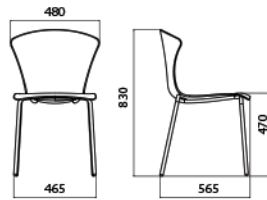

GLOSSY 3D WOOD

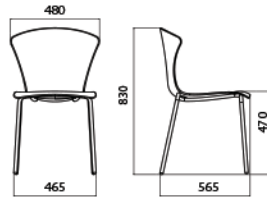

TELAIO/Frame

TELAIO IN ACCIAIO

Steel frame



AC01
Cromato
Chromium-plated

AC101
Verniciato bianco
lucido
Polished white
painted

AC102
Verniciato nero lucido
Polished black painted

SCocca/Shell

POLICARBONATO
TRASPARENTE

Transparent
polycarbonate



PC103
Ghiaccio
Ice

PC104
Fumé
Smoke-grey

POLICARBONATO
COPRENTE

Solid colour
polycarbonate



PC101
Ghiaccio
Ice

PC102
Nero
Black

PC114
Rosso
Red

PC128
Tabacco
Tobacco

SCocca IN LEGNO 3D

Solid oak



LR01
Rovere sbiancato
Whitened oak

LR02
Rovere wengè
Wenge-stain oak

LR03
Rovere naturale
Natural oak

LR04
Rovere verniciato ocra
Ochre painted oak

LR05
Rovere verniciato
bordeaux
Bordeaux painted oak



LR06
Rovere verniciato
antracite
Anthracite
painted oak

LR07
Rovere verniciato
verde
Green painted oak

LR08
Rovere verniciato
nero
Black painted oak

LF01
Faggio naturale
Natural beech

LF02
Faggio wengè
Wengè-stain beech

TAPPEZZERIA

Upholstery

Canvas Kvadrat
Cava 3 Kvadrat
Divina 3 Kvadrat

Divina Melange 2
Kvadrat
Outback Kvadrat

Field Kvadrat
Umami Kvadrat

Flash No-shrink
Byte





PORTA VENEZIA

Wood, plastic, and a classic design make Porta Venezia a product that fits harmoniously into any furnishing style with its numerous combinations of colour and covers. The family includes the chair, kitchen stool, bar-stool and lounge versions, and also extends to include several table versions.



PORTA VENEZIA

DESIGN:
DORIGO DESIGN

SOLID BEECH WOOD FRAME
WITH POLYPROPYLENE SEAT AND
BACKREST. AVAILABLE VERSIONS
WITH ONLY SEAT OR SEAT AND
BACK UPHOLSTERED IN LEATHER,
ECO-LEATHER OR FABRIC.

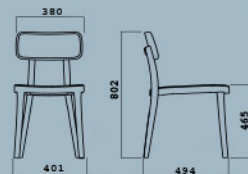

— THE CONCEPT OF THIS CHAIR ORIGINALLY DESIGNED TO BE USED IN BARS AND CAFÉS IS GIVEN A BRAND NEW LOOK THROUGH NEW PAINTINGS TO ALLOW USE IN MINIMALIST LIVING ROOMS AND RETAIL SPACES WITH A POP STYLE.

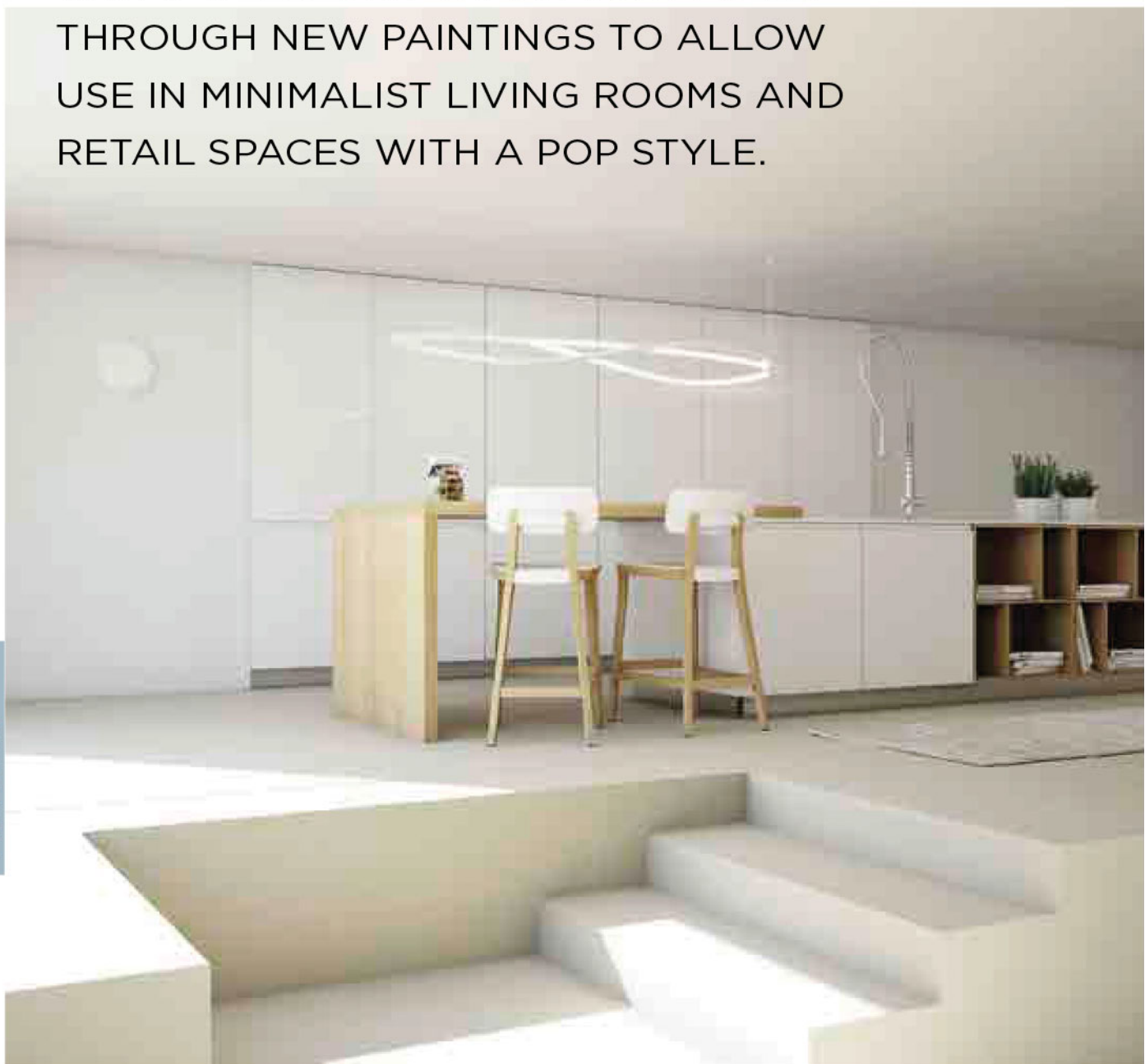



PORTA VENEZIA
LOUNGE



PORTA VENEZIA
KITCHEN STOOL



PORTA VENEZIA
CHAIR

Porta Venezia Bar Table

PORTA VENEZIA CHAIR

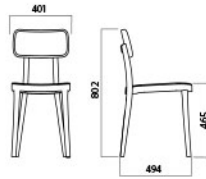
RIVESTIMENTO
UpholsteryIMPILABILITÀ
StackabilityESTERNO
Outdoor

PORTA VENEZIA KITCHEN STOOL

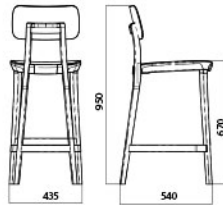

PORTA VENEZIA KITCHEN STOOL

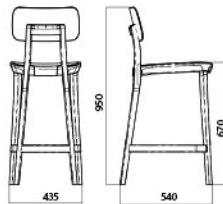

PORTA VENEZIA LOUNGE

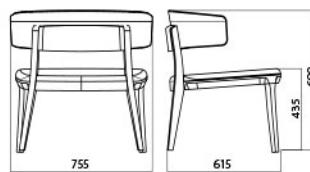

TELAIO/Frame

MASSELLO DI FAGGIO

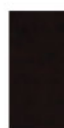

Solid beech

MAFGV
Faggio naturale
Natural beech

MAFC3
Faggio wengè
Wenge-stain beech

MAFLG6
Faggio laccato
bianco
White lacquered
beech

MAF104
Faggio tinto nero
Black lacquered
beech

SEDILE E SCHIENALE

Seat and backrest

POLIPROPILENE

Polypropylene



PP01
Nero
Black

PP20
Bianco
White

PP21
Grigio perla
Pearl grey

PP512
Verde avocado
Avocado green



PP22
Tabacco
Tobacco

PP102C
Giallo mimosa
Mimosa yellow

PP3020
Rosso
Red

TAPPEZZERIA

Upholstery

Canvas Kvadrat
Cava 3 Kvadrat
Divina 3 Kvadrat

Divina Melange 2
Kvadrat
Outback Kvadrat

Field Kvadrat
Umami Kvadrat

Flash No-shrink
Byte

PELLE FIORE

Full-grain leather

ECOPELLE

Eco leather







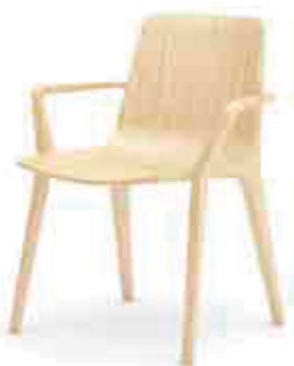

SEAME

The synthesis of Infniti's know-how in woodwork: a lightweight chair, with elegant lines in the curve of the wood. The Seame family extends all its characteristics to the version with arms and the stool too, the latter is available in two different heights and has a painted steel footrest.



SEAME

DESIGN:
KLAUS NOLTING

—
3D CURVED OAK PLYWOOD
SHELL BONDED ONTO A SOLID
WOOD FRAME. MANY DIFFERENT
COLOURS TO CHOOSE FROM.

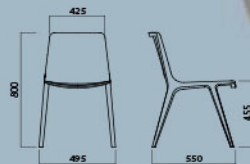

— TOTALLY ENVIRONMENTALLY-FRIENDLY CHAIR, PERFECT FOR SETTINGS FEATURING A SCANDINAVIAN DESIGN AND NEUTRAL, COLD MODERN COLOURS.

CONCEIVED FOR RESIDENTIAL SETTINGS, SEAME IS ALSO PERFECT FOR CONTRACT USE IN LIBRARIES, READING AREAS, AND PUBLIC SPACES.





SEAME
STOOL



SEAME
CHAIR

RIVESTIMENTO
UpholsteryIMPILABILITÀ
StackabilityESTERNO
Outdoor

SEAME 4 LEGS

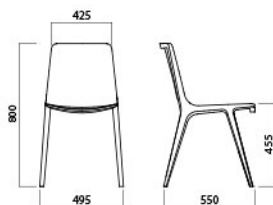

SEAME 4 LEGS WITH ARMS



SEAME KITCHEN STOOL

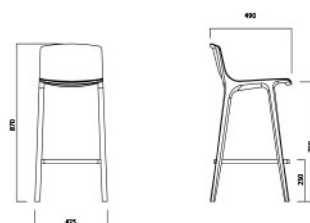

SEAME BAR STOOL

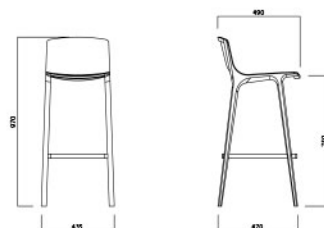

TELAIO/Frame

MASSELLO DI FAGGIO

Solid beech



MAFGV
Faggio naturale
Natural beech

MAFC3
Faggio wengè
Wenge-stain beech

MASSELLO DI ROVERE

Solid oak



MAR01
Rovere sbiancato
Whitened oak

MAR02
Rovere wengè
Wenge-stain oak

MAR03
Rovere naturale
Natural oak

MAR04
Rovere verniciato ocra
Ochre painted oak



MAR05
Rovere verniciato bordeaux
Bordeaux painted oak

MAR06
Rovere verniciato antracite
Anthracite painted oak

MAR07
Rovere verniciato verde
Green painted oak

MAR08
Rovere verniciato nero
Black painted oak

POGGIAPIEDI/Footrest

ACCIAIO

Steel



AC103
Verniciato grigio lucido
Polished grey painted

AC30
Verniciato bianco opaco
White matt painted

AC31
Verniciato nero opaco
Black matt painted









EMMA

Simple, well-defined lines, Emma is a solid oak or beech chair that is also available with an upholstered panel. The stool version has a more minimal seat and can also be upholstered.



EMMA

DESIGN:
PAOLO FAVARETTO

—
THE FRAME, CHARACTERIZED BY AN ELEGANT CROSSBAR PARALLEL TO THE SEAT, IS CONNECTED TO THE SHELL THROUGH 4 VISIBLE HOLES WITHOUT ANY SCREWS.

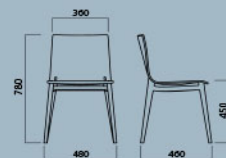

—
EMMA WILL FIND ITS PERFECT LOCATION IN RESIDENTIAL SPACES. THE STOOL VERSION IS BEST ENHANCED IN MODERN URBAN INTERIORS.



EMMA
BAR STOOL

EMMA CHAIR

RIVESTIMENTO
Upholstery

IMPILABILITÀ
Stackability

ESTERNO
Outdoor

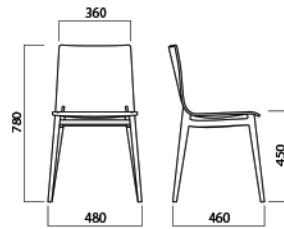

EMMA KITCHEN STOOL

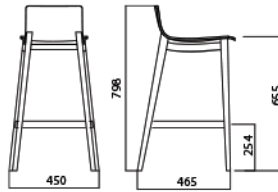

EMMA BAR STOOL

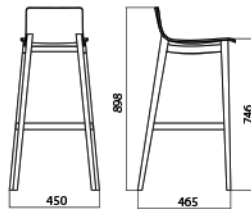

TELAIO/Frame

MASSELLO DI FAGGIO

Solid beech



MAFGV
Faggio naturale
Natural beech



MAFC3
Faggio wengè
Wenge-stain beech

MASSELLO DI ROVERE

Solid oak



MAR01
Rovere sbiancato
Whitened oak



MAR02
Rovere wengè
Wenge-stain oak



MAR03
Rovere naturale
Natural oak



MAR04
Rovere verniciato ocra
Ochre painted oak



MAR05
Rovere verniciato bordeaux
Bordeaux painted oak



MAR06
Rovere verniciato antracite
Anthracite painted oak



MAR07
Rovere verniciato verde
Green painted oak



MAR08
Rovere verniciato nero
Black painted oak

TAPPEZZERIA

Upholstery

Canvas Kvadrat
Cava 3 Kvadrat
Divina 3 Kvadrat

Divina Melange 2 Kvadrat
Outback Kvadrat

Field Kvadrat
Umami Kvadrat

Flash No-shrink Byte

PELLE FIORE

Full-grain leather

ECOPELLE

Eco leather





PENELOPE

Square design and vintage style, Penelope reinterprets the director's chair with character and originality. The seat can be covered in fabric for a more informal look.



PENELOPE

DESIGN:
ALESSANDRO MASTURZO

THE ALUMINIUM ARMS AND SMALL BACKREST ARE SUPPORTED BY A SOLID BEECH WOOD FRAME WITH NATURAL, WHITE LACQUERED OR BLACK STAINED FINISH.

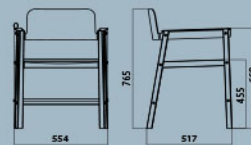



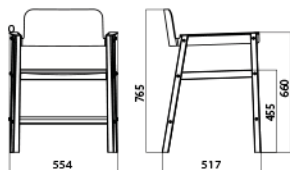

TELAIO/Frame

MASSELLO DI FAGGIO

Solid beech



MAFGV
Faggio naturale
Natural beech



MAFC3
Faggio wengè
Wenge-stain beech



MAFLG6
Faggio laccato bianco
White lacquered beech



MAF104
Faggio tinto nero
Black lacquered beech

SCHIENALE/Backrest

ALLUMINIO

Aluminium



AL01
Verniciato gofrato bianco
White embossed painted



AL03
Verniciato gofrato antracite
Anthracite embossed painted

TAPPEZZERIA

Upholstery

Canvas Kvadrat
Cava 3 Kvadrat
Divina 3 Kvadrat

Divina Melange 2 Kvadrat
Outback Kvadrat

Field Kvadrat
Umami Kvadrat

Flash No-shrink
Byte





PURE LOOP BINUANCE

Binuance develops the colours, material, and technology of the Pure Loop family. The extremely elegant two-colour one-piece shell is obtained from a single polypropylene injection and is available in seven versions, all tone-sur-tone.



PURE LOOP BINUANCE

DESIGN:
CLAUS BREINHOLT

NEW "RETRO" SOLID OAK FRAME RECALLING STARK SCANDINAVIAN DESIGN WITH A PURE WHITE/OFF WHITE SHELL.

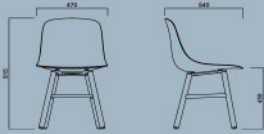

—
 THE MATT COLOUR COMBINATIONS MATCHED TO A VARIETY OF FRAMES MAKE THIS FAMILY SUITABLE FOR COUNTLESS APPLICATIONS AND SETTINGS: CASUAL, CHIC OR TOTAL-WHITE.



PURE LOOP BINUANCE
 RETRO



PURE LOOP BINUANCE
 4 LEGS



PURE LOOP BINUANCE SLEDGE



PURE LOOP BINUANCE 4 STAR ALUMINIUM BASE

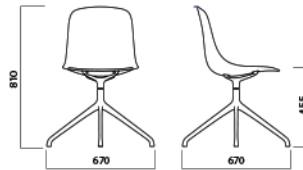

PURE LOOP BINUANCE SWIVEL WITH CASTORS

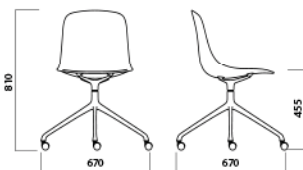

PURE LOOP BINUANCE RETRO

RIVESTIMENTO
UpholsteryIMPILABILITÀ
StackabilityESTERNO
Outdoor

PURE LOOP BINUANCE WOODEN LEGS



PURE LOOP BINUANCE KITCHEN STOOL

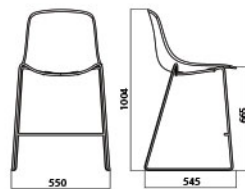

PURE LOOP BINUANCE BAR STOOL

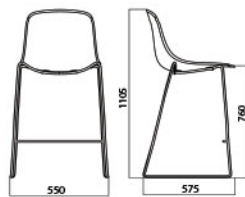

TELAIO/Frame**TELAIO IN ACCIAIO**

Steel frame

AC01
Cromato
*Cromium-plated***AC30**
Verniciato bianco
opaco
*White matt painted***AC31**
Verniciato nero
opaco
*Black matt painted***AC32**
Verniciato grigio
opaco
*Grey matt painted***BASE IN ALLUMINIO**

Steel frame

AL07
Pulito
*Polished***AL30**
Verniciato bianco
opaco
*White matt painted***AL31**
Verniciato opaco
nero
*Black matt painted***AL32**
Verniciato opaco
grigio
Grey embossed
*painted***SCocca/Shell****POLIPROPILENE**

Polypropylene

PP28/PP27
Avorio/Curry
*Ivory/Curry***PP30/PP29**
Verde kaki/Verde
oliva
Khaki green/Olive
*green***PP33/PP34**
Pesca/Arancio
Carota
Peach/Carrot
*orange***PP9010/PP9001**
Bianco puro/Bianco
crema
Pure white/Off-white**PP32/PP31**
Grigio ardesia/Nero
carbone
Slate grey/Coal
*black***PP24/PP23**
Grigio luce/Grigio
medio
Light grey/Medium
*grey***PP26/PP25**
Beige/Biscotto
*Beige/Biscuit***TELAIO RETRO/Retro Frame****LEGNO MASSELLO**

Solid wood

MAR03
Rovere naturale
*Natural oak***MAR08**
Rovere verniciato
nero
*Black painted oak***MAR06**
Rovere verniciato
antracite
Anthracite painted
*oak***MAFLG6**
Faggio laccato
bianco
White lacquered
*beech***GAMBE LEGNO/Wooden Legs****MASSELLO DI FAGGIO**

Solid beech

MAFGV
Faggio naturale
*Natural beech***MAFC3**
Faggio wengè
*Wenge-stain beech***MAFLG6**
Faggio laccato
bianco
White lacquered
beech





PURE LOOP

An even more functional design, without arms: pure. A large subfamily that is available with the same Loop frames in plastic, upholstered and 3D curved wood versions.



PURE LOOP

DESIGN:
CLAUS BREINHOLT

—
OPAQUE OR TRANSPARENT POLISHED POLYCARBONATE SHELL RESTS ON A CHROMIUM-PLATED OR PAINTED STEEL FOUR-LEG FRAME MADE ALLOWING THE CHAIR TO BE STACKED.

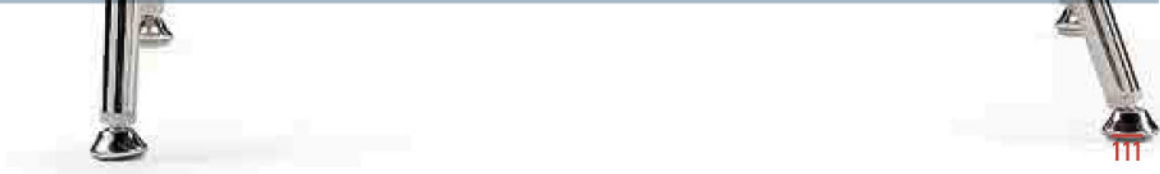
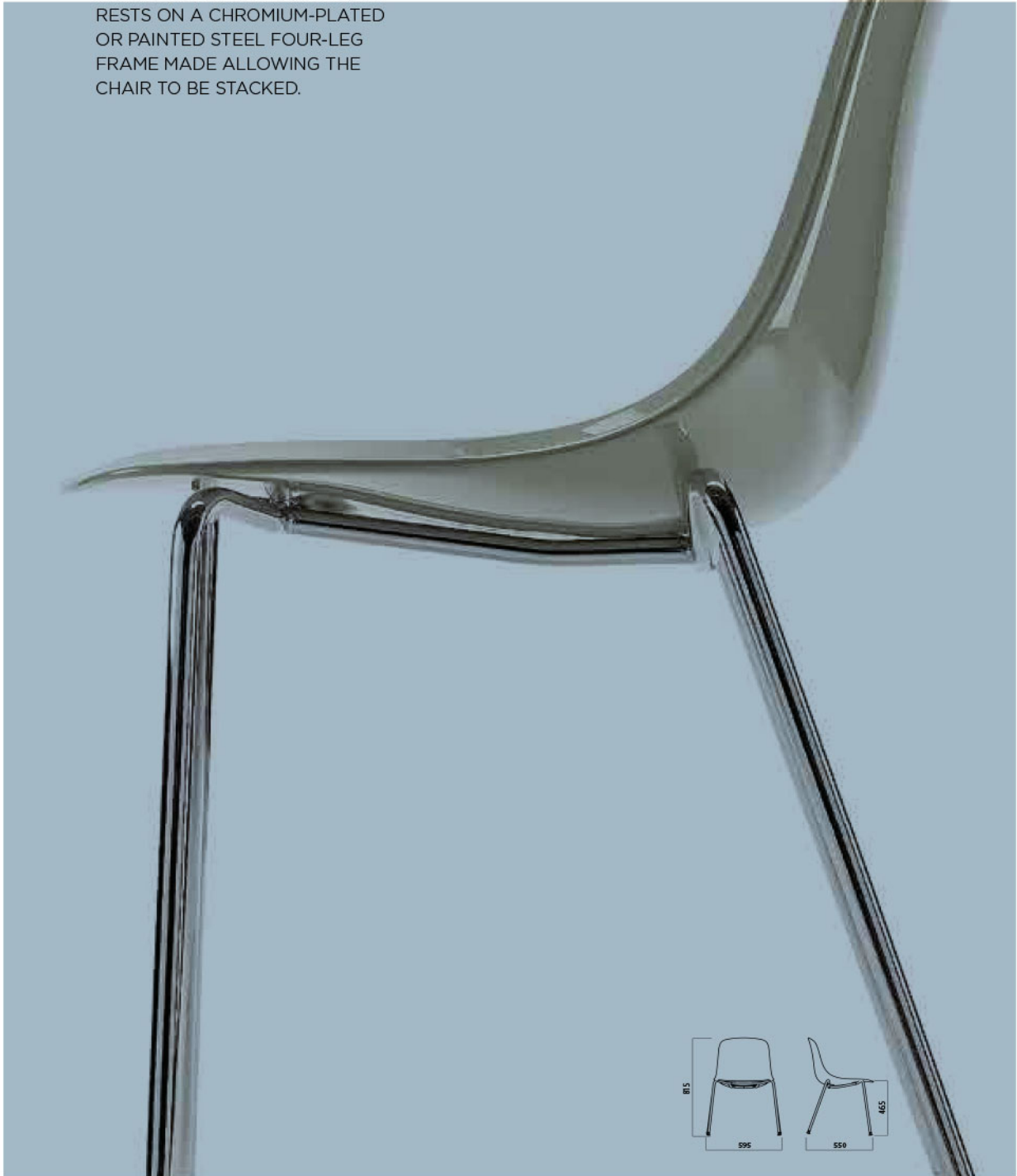

— PURE LOOP IS SYNONYMOUS WITH CHARACTER, A CHOICE THAT WILL PERFECTLY FIT IN WITH THE MOST SOPHISTICATED LIVING AREAS AND WITH BARS AND RESTAURANTS CHARACTERISED BY AN INFORMAL OR VINTAGE STYLE.

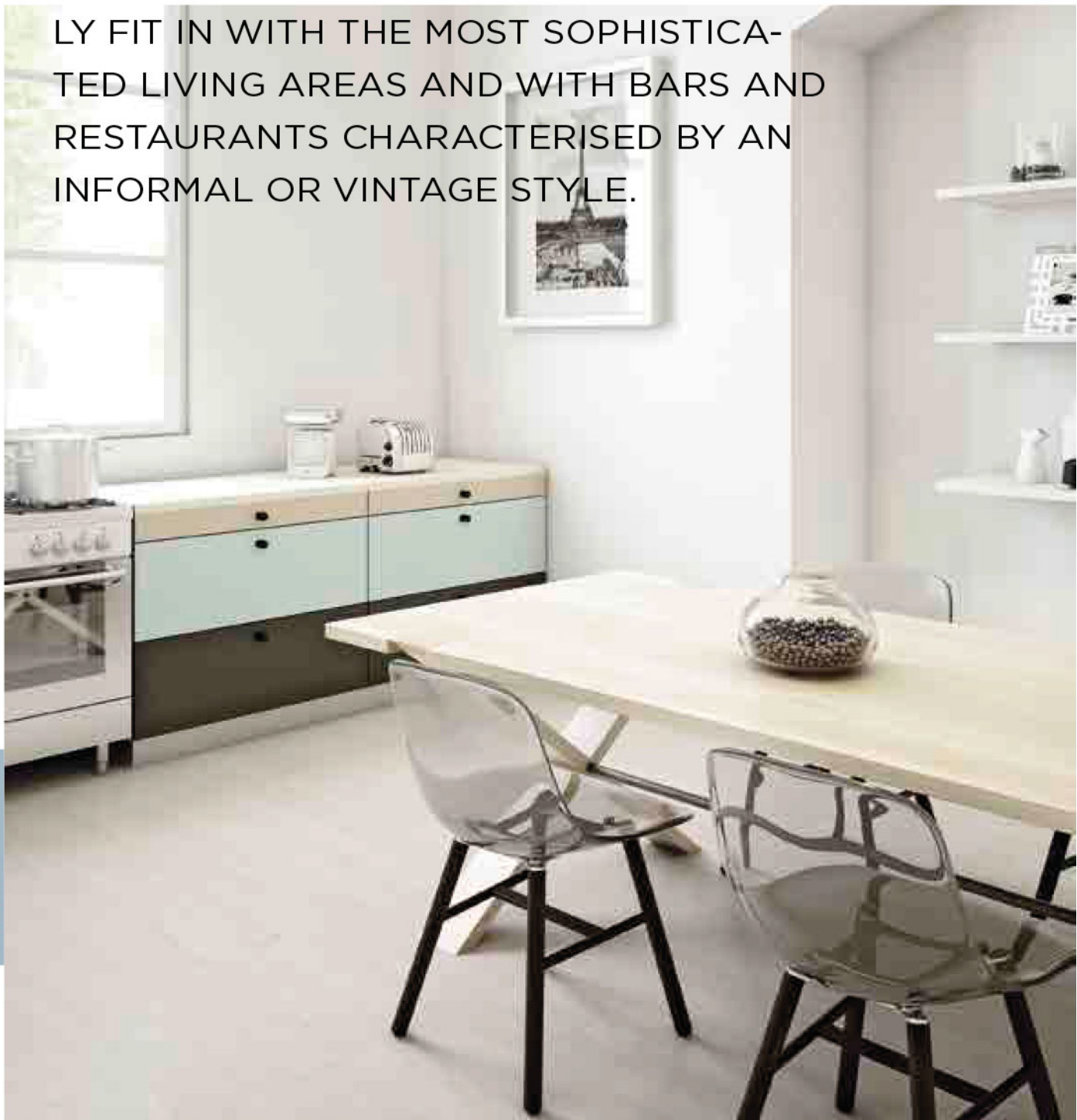



PURE LOOP
4 LEGS





PURE LOOP SLEDGE



PURE LOOP 4 STAR ALUMINIUM BASE

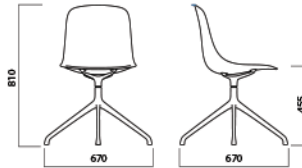

PURE LOOP SWIVEL WITH CASTORS

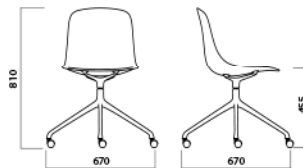

PURE LOOP RETRO

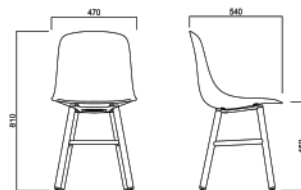

PURE LOOP WOODEN LEGS

RIVESTIMENTO
Upholstery

IMPILABILITÀ
Stackability

ESTERNO
Outdoor



PURE LOOP KITCHEN STOOL

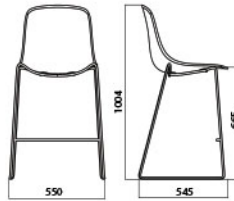

PURE LOOP BAR STOOL

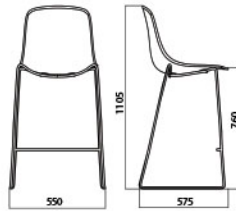

PURE LOOP LOUNGE

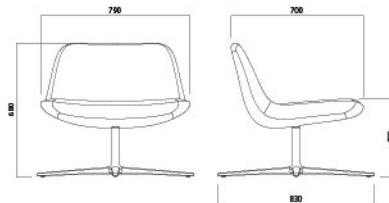

PANNELLINO SEDILE/Seat panel



FELTRO

Felt



F003



F008



F009



F011



F015

TELAIO/Frame
TELAIO IN ACCIAIO

Steel frame

AC01
Cromato
 Cromium-plated

AC30
Verniciato bianco opaco
 White matt painted

AC31
Verniciato nero opaco
 Black matt painted

AC32
Verniciato grigio opaco
 Grey matt painted

BASE IN ALLUMINIO

Steel frame

AL07
Pulito
 Polished

AL30
Verniciato bianco opaco
 White matt painted

AL31
Verniciato opaco nero
 Black matt painted

AL32
Verniciato opaco grigio
 Grey embossed painted

SCOCCA/Shell
POLICARBONATO TRASPARENTE

Transparent polycarbonate

PC103
Ghiaccio
 Ice

PC104
Fumé
 Smoke-grey

POLICARBONATO COPRENTE

Solid colour polycarbonate

PC101
Bianco
 White

PC102
Nero
 Black

PC114
Rosso
 Red

PC130
Verde foglia
 Green leaf

PC117
Grigio siliceo
 Silica grey

PC118
Arancione
 Orange

TELAIO RETRO/Retro Frame
LEGNO MASSELLO

Solid wood

MAR03
Rovere naturale
 Natural oak

MAR08
Rovere verniciato nero
 Black painted oak

MAR06
Rovere verniciato antracite
 Anthracite painted oak

MAFLG6
Faggio laccato bianco
 White lacquered beech

GAMBE LEGNO/Wooden Legs
MASSELLO DI FAGGIO

Solid beech

MAFGV
Faggio naturale
 Natural beech

MAFC3
Faggio wengè
 Wenge-stain beech

MAFLG6
Faggio laccato bianco
 White lacquered beech

TAPPEZZERIA

Upholstery

Canvas Kvadrat
Cava 3 Kvadrat
Divina 3 Kvadrat
Divina Melange 2 Kvadrat
Outback Kvadrat
Field Kvadrat
Umami Kvadrat
Flash No-shrink
Byte
PELLE FIORE

Full-grain leather

ECOPELLE

Eco leather

RIVESTIMENTO
Upholstery

IMPILABILITÀ
Stackability

ESTERNO
Outdoor

PURE LOOP 4 LEGS



PURE LOOP 3D WOOD SLEDGE



PURE LOOP 3D WOOD WOODEN LEGS



PURE LOOP 3D WOOD 4 STAR ALUMINIUM BASE

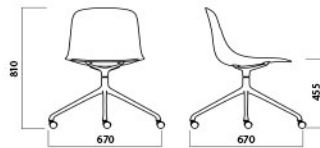

LOOP 3D WOOD SWIVEL WITH CASTORS

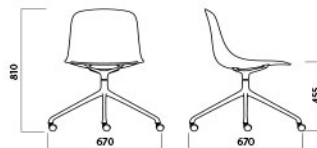



FELTRO

Felt



F003



F008



F009



F011



F015

TELAIO/Frame

TELAIO IN ACCIAIO

Steel frame



AC01
Cromato
Cromium-plated



AC30
Verniciato bianco
opaco
White matt painted



AC31
Verniciato nero
opaco
Black matt painted



AC32
Verniciato grigio
opaco
Grey matt painted

BASE IN ALLUMINIO

Steel frame



AL07
Pulito
Polished



AL30
Verniciato bianco
opaco
White matt painted



AL31
Verniciato opaco
nero
Black matt painted



AL32
Verniciato opaco
grigio
Grey embossed
painted

SCocca/Shell

LEGNO MULTISTRATO IN 3D

3D Plywood



LR01
Rovere sbiancato
Whitened oak



LR02
Rovere wengè
Wenge-stain oak



LR03
Rovere naturale
Natural oak



LR04
Rovere verniciato ocra
Ochre painted oak



LR05
Rovere verniciato
bordeaux
Bordeaux painted
oak



LR06
Rovere verniciato
antracite
Anthracite
painted oak



LR07
Rovere verniciato
verde
Green painted oak



LR08
Rovere verniciato nero
Black painted oak

GAMBE/Legs

MASSELLO DI FAGGIO

Plywood



MAFGV
Faggio naturale
Natural beech



MAFC3
Faggio wengè
Wenge-stain beech



MAFLG6
Faggio laccato
bianco
White lacquered
beech

TAPPEZZERIA

Upholstery

Canvas Kvadrat
Cava 3 Kvadrat
Divina 3 Kvadrat

Divina Melange 2
Kvadrat
Outback Kvadrat

Field Kvadrat
Umami Kvadrat

Flash No-shrink
Byte

PELLE FIORE

Full-grain leather

ECOPELLE

Eco leather





PURE LOOP MINI

The "Pure" shell becomes "Mini", assembled on different types of stool frames: four legs, Rod, Dandy, and the brand new Updown. All the versions have a polypropylene shell that can also be upholstered, while Dandy and Updown also offer the possibility of a seat in 3D curved wood.



PURE LOOP MINI

DESIGN:
CLAUS BREINHOLT

STOOL WITH DANDY FRAME
MADE OF WHITE PAINTED STEEL
ROD, WITH FOOTREST AND
WHITE POLYPROPYLENE SHELL.

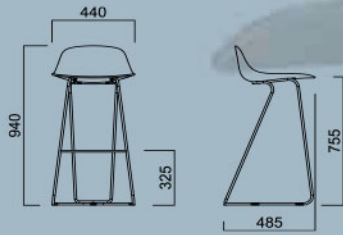

— INTERIORS FEATURING A CONTEMPORARY ELEGANT APPEARANCE OR MATCHING MODERN AND VINTAGE STYLES: PURE LOOP MINI IS A SMART SOLUTION COMBINING SOPHISTICATION AND ERGONOMICS.





PURE LOOP MINI
UPDOWN STOOL



PURE LOOP MINI
DANDY STOOL

RIVESTIMENTO
UpholsteryIMPILABILITÀ
StackabilityESTERNO
Outdoor

PURE LOOP MINI KITCHEN 4 LEGS

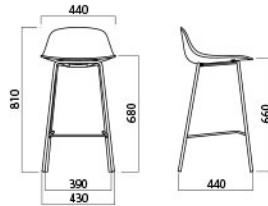

PURE LOOP MINI BAR 4 LEGS

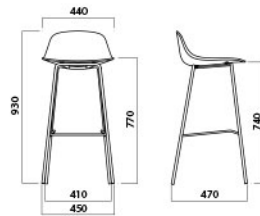

PURE LOOP MINI ROD KITCHEN

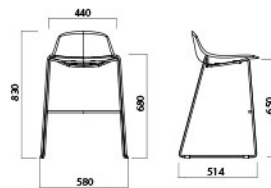

PURE LOOP MINI ROD BAR

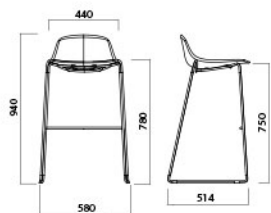

PURE LOOP MINI DANDY KITCHEN

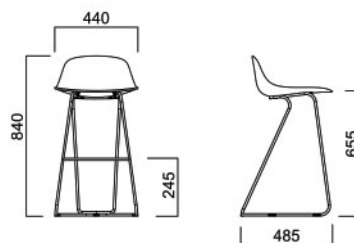

PURE LOOP MINI DANDY BAR

RIVESTIMENTO
Upholstery

IMPILABILITÀ
Stackability

ESTERNO
Outdoor

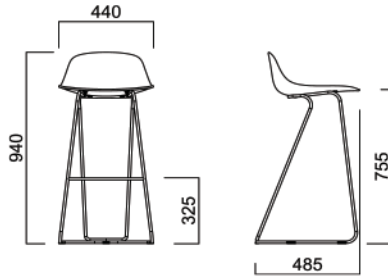

PURE LOOP MINI UPDOWN

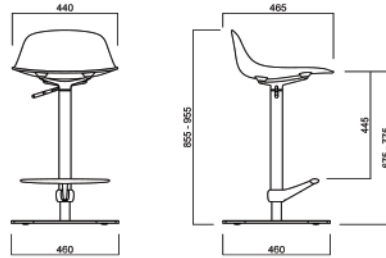

TELAIO/Frame

TELAIO IN ACCIAIO

Steel frame



AC01
Cromato
Cromium-plated



AC30
Verniciato bianco
opaco
White matt painted



AC31
Verniciato nero
opaco
Black matt painted



AC32
Verniciato grigio
opaco
Grey matt painted

Nella versione Updown poggipiedi in alluminio in tinta con la base.
In Updown version footrest in the same colour as the base.

SCocca/Shell

POLIPROPILENE

Polypropylene



PP20
Bianco
White



PP01
Nero
Black



PP3020
Rosso
Red



PP514
Sabbia
Sand



PP30
Verde kaki
Khaki green



PP33
Arancio carota
Carrot orange

TAPPEZZERIA

Upholstery

Canvas Kvadrat
Cava 3 Kvadrat
Divina 3 Kvadrat

Divina Melange 2
Kvadrat
Outback Kvadrat

Field Kvadrat
Umami Kvadrat

Flash No-shrink
Byte

PELLE FIORE

Full-grain leather

ECOPELLE

Eco leather

PURE LOOP MINI DANDY KITCHEN 3D WOOD

RIVESTIMENTO
UpholsteryIMPILABILITÀ
StackabilityESTERNO
Outdoor

PURE LOOP MINI DANDY BAR 3D WOOD



PURE LOOP MINI UPDOWN 3D

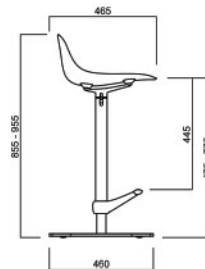

TELAIO/Frame**TELAIO IN ACCIAIO**

Steel frame

AC01*Cromato**Cromium-plated***AC30***Verniciato bianco**opaco**White matt painted***AC31***Verniciato nero**opaco**Black matt painted***AC32***Verniciato grigio**opaco**Grey matt painted*

Nella versione Updown poggiapiedi in alluminio in tinta con la base.
In Updown version footrest in the same colour as the base.

SCocca/Shell**LEGNO MULTISTRATO IN 3D**

3D Plywood

LR01*Rovere sbiancato**Whitened oak***LR02***Rovere wengè**Wenge-stain oak***LR03***Rovere naturale**Natural oak***LR04***Rovere verniciato ocra**Ochre painted oak***LR05***Rovere verniciato
bordeaux**Bordeaux painted
oak***LR06***Rovere verniciato
antracite**Anthracite
painted oak***LR07***Rovere verniciato
verde**Green painted oak***LR08***Rovere verniciato nero**Black painted oak*





LOOP

The first legendary family created by Claus Breinholt and the first one-piece shell in the world with arms in 3D curved wood. Predecessor of a long series of subfamilies and versions, including the shell without arms and "mini" for stools.



LOOP

DESIGN:
CLAUS BREINHOLT

—
STACKABLE CHAIR WITH CHROMIUM-PLATED OR PAINTED STEEL
FOUR-LEG FRAME, SHELL MADE
OF POLYCARBONATE WITH ARMS.

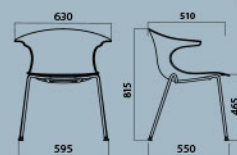

CHAIRS

—
A PLAIN CONTEMPORARY DESIGN THAT IS SUITABLE FOR THE MOST DIVERSE FURNITURE STYLES. IT COMES IN THE PLASTIC, WOOD OR UPHOLSTERED FINISH AND IN THE TWO LOUNGE VERSIONS WITH MATCHING FOOTREST. IDEAL FOR WAITING AREAS.

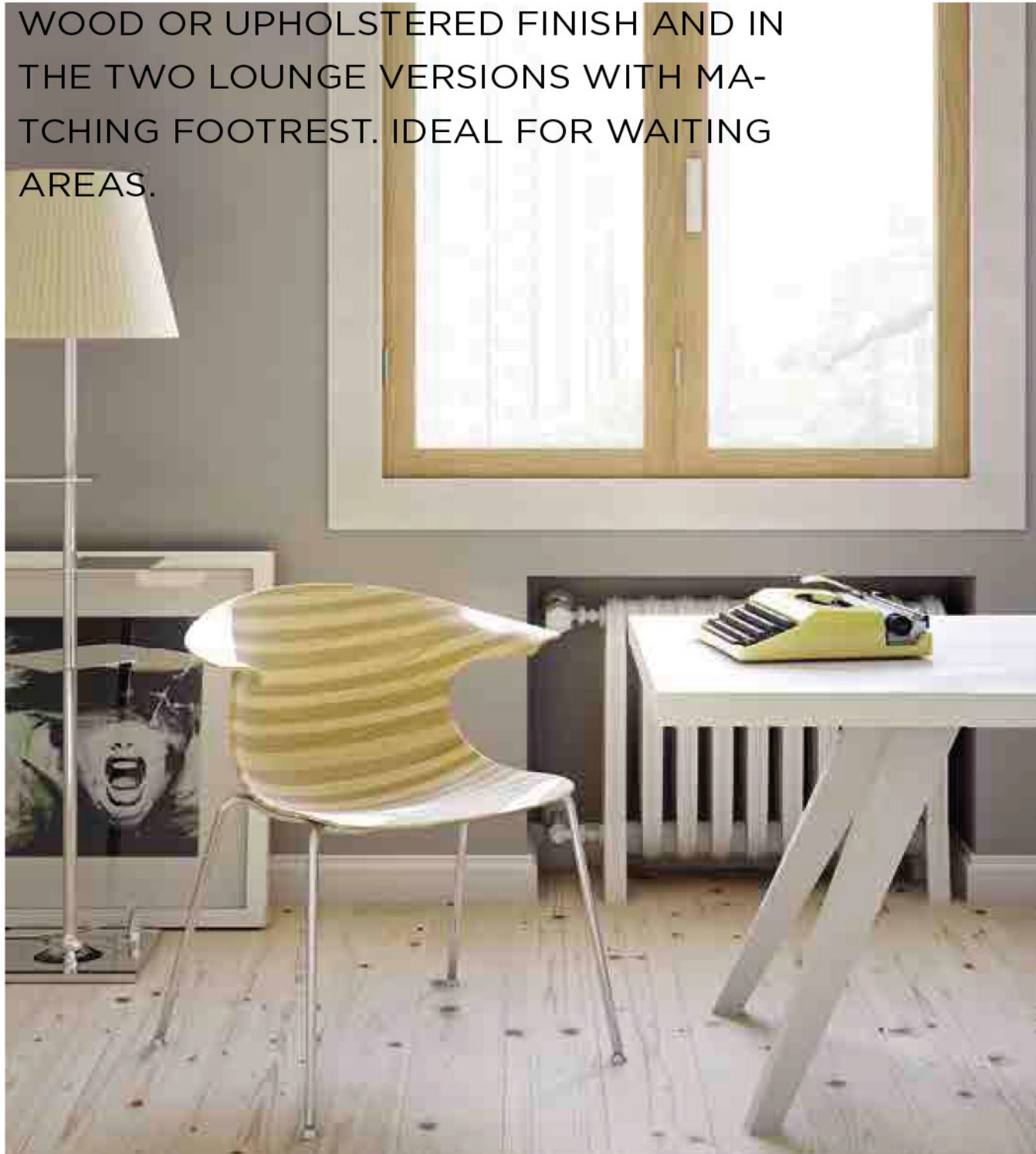



LOOP
LOUNGE
with Pouff



LOOP
4 LEGS



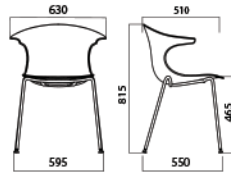

LOOP SLEDGE

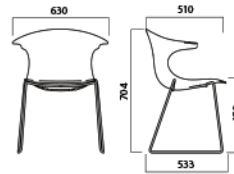

LOOP 4 STAR ALUMINIUM BASE

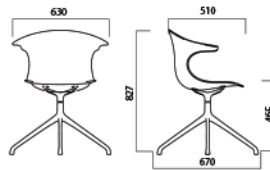

LOOP SWIVEL WITH CASTORS

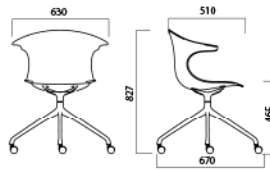

LOOP RETRO



LOOP WOODEN LEGS

RIVESTIMENTO
UpholsteryIMPILABILITÀ
StackabilityESTERNO
Outdoor

LOOP KITCHEN STOOL

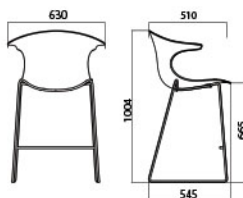

LOOP BAR STOOL

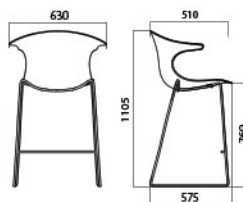

PANNELLINO SEDILE/Seat panel



FELTRO

Felt



F003



F008



F009



F011



F015

TELAIO/Frame
TELAIO IN ACCIAIO

Steel frame

AC01
Cromato
 Cromium-plated

AC30
Verniciato bianco opaco
 White matt painted

AC31
Verniciato nero opaco
 Black matt painted

AC32
Verniciato grigio opaco
 Grey matt painted

BASE IN ALLUMINIO

Steel frame

AL07
Pulito
 Polished

AL30
Verniciato bianco opaco
 White matt painted

AL31
Verniciato opaco nero
 Black matt painted

AL32
Verniciato opaco grigio
 Grey embossed painted

SCocca/Shell
POLICARBONATO TRASPARENTE

Transparent polycarbonate

PC103
Ghiaccio
 Ice

PC104
Fumé
 Smoke-grey

POLICARBONATO COPRENTE

Solid colour polycarbonate

PC101
Bianco
 White

PC102
Nero
 Black

PC114
Rosso
 Red

PC130
Verde foglia
 Green leaf

PC117
Grigio siliceo
 Silica grey

PC118
Arancione
 Orange

TELAIO RETRO/Retro Frame
LEGNO MASSELLO

Solid wood

MAR03
Rovere naturale
 Natural oak

MAR08
Rovere verniciato nero
 Black painted oak

MAR06
Rovere verniciato antracite
 Anthracite painted oak

MAFLG6
Faggio laccato bianco
 White lacquered beech

GAMBE LEGNO/Wooden Legs
MASSELLO DI FAGGIO

Solid beech

MAFGV
Faggio naturale
 Natural beech

MAFC3
Faggio wengè
 Wenge-stain beech

MAFLG6
Faggio laccato bianco
 White lacquered beech

TAPPEZZERIA

Upholstery

Canvas Kvadrat
Cava 3 Kvadrat
Divina 3 Kvadrat
Divina Melange 2 Kvadrat
Outback Kvadrat
Field Kvadrat
Umami Kvadrat
Flash No-shrink
Byte
PELLE FIORE

Full-grain leather

ECOPELLE

Eco leather

RIVESTIMENTO
Upholstery

IMPILABILITÀ
Stackability

ESTERNO
Outdoor

LOOP 3D WOOD 4 LEGS

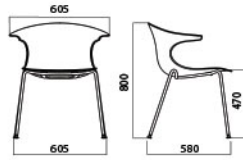

LOOP 3D WOOD SLEDGE

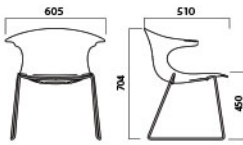

LOOP 3D WOOD 4 STAR ALUMINIUM BASE

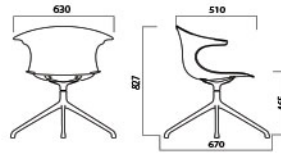

LOOP 3D WOOD SWIVEL WITH CASTORS

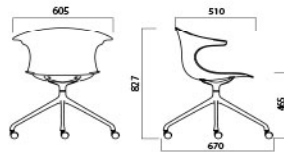

LOOP 3D WOOD WOODEN LEGS



PANNELLINO SEDILE/Seat panel



FELTRO

Felt



F003



F008



F009



F011



F015

TELAIO/Frame

TELAIO IN ACCIAIO

Steel frame



AC01
Cromato
Cromium-plated



AC30
Verniciato bianco
opaco
White matt painted



AC31
Verniciato nero
opaco
Black matt painted



AC32
Verniciato grigio
opaco
Grey matt painted

BASE IN ALLUMINIO

Steel frame



AL07
Pulito
Polished



AL30
Verniciato bianco
opaco
White matt painted



AL31
Verniciato opaco
nero
Black matt painted



AL32
Verniciato opaco
grigio
Grey embossed
painted

SCocca/Scocca

LEGNO MULTISTRATO IN 3D

3D Plywood



LR01
Rovere sbiancato
Whitened oak



LR02
Rovere wengè
Wenge-stain oak



LR03
Rovere naturale
Natural oak



LR04
Rovere verniciato ocra
Ochre painted oak



LR05
Rovere verniciato
bordeaux
Bordeaux painted
oak



LR06
Rovere verniciato
antracite
Anthracite
painted oak



LR07
Rovere verniciato
verde
Green painted oak



LR08
Rovere verniciato nero
Black painted oak

GAMBE LEGNO/Wooden Legs

MASSELLO DI FAGGIO

Plywood



MAFGV
Faggio naturale
Natural beech



MAFG3
Faggio wengè
Wenge-stain beech



MAFLG6
Faggio laccato
bianco
White lacquered
beech

RIVESTIMENTO
UpholsteryIMPILABILITÀ
StackabilityESTERNO
Outdoor

LOOP 3D VINTERIO 4 LEGS

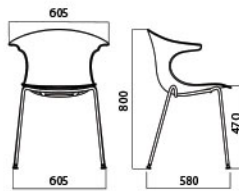

LOOP 3D VINTERIO SLEDGE

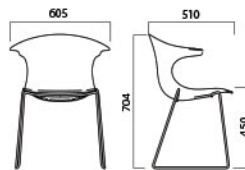

LOOP 3D VINTERIO 4 STAR ALUMINIUM BASE

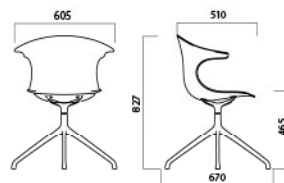

LOOP 3D VINTERIO SWIVEL WITH CASTORS

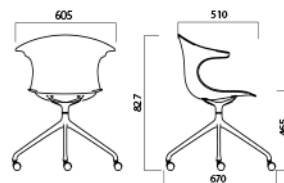

TELAIO/Frame

TELAIO IN ACCIAIO

Steel frame



AC01
Cromato
Cromium-plated

AC30
Verniciato bianco
opaco
White matt painted

AC31
Verniciato nero
opaco
Black matt painted

AC32
Verniciato grigio
opaco
Grey matt painted

BASE IN ALLUMINIO

Steel frame



AL07
Pulito
Polished

AL30
Verniciato bianco
opaco
White matt painted

AL31
Verniciato opaco
nero
Black matt painted

AL32
Verniciato opaco
grigio
Grey embossed
painted

SCocca/Shell

LEGNO MULTISTRATO IN 3D

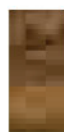

3D Plywood

LV1
Classic Sapeli Mocca

LV07
Classic Brown Olive
Ash

LV03
Classic Black Cherry
Elegant

LV04
Classic Amazakoue
Elegant

LV05
Nimbus Sapeli
Sycamore

LV06
Stratus Superior
American Walnut

LOOP LOUNGE HEADREST

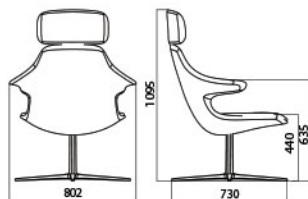
RIVESTIMENTO
UpholsteryIMPILABILITÀ
StackabilityESTERNO
Outdoor

LOOP LOUNGE LOW

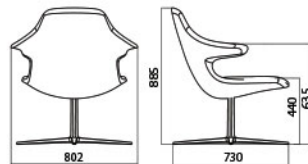

LOOP LOUNGE POUFF

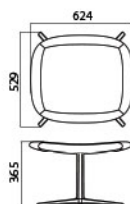

BASE IN ALLUMINIO



Steel frame

AL07

AL30

AL31

Pulito

Verniciato bianco

Verniciato opaco

Polished

opaco

nero

White matt painted

Black matt painted

TAPPEZZERIA

PELLE FIORE

ECOPELLE

Upholstery

Canvas Kvadrat

Divina Melange 2

Field Kvadrat

Flash No-shrink

Full-grain leather

Eco leather

Cava 3 Kvadrat

Kvadrat

Umami Kvadrat

Byte

Divina 3 Kvadrat

Outback Kvadrat









FIORELLINA

Lightweight and practical, this range is characterised by considerable manufacturing complexity. In fact, at the base there is a technology that makes it possible to obtain four different versions of the product from one mould: with solid or perforated backrest, both with or without arms.



FIORELLINA

DESIGN:
FABRIZIO BATONI

—
ONE-PIECE INJECTION-MOULDED
CHAIR MADE OF GLASS-FIBRE
REINFORCED POLYPROPYLENE.
STACKABLE AND AVAILABLE IN A
NUMBER OF FINISHES.

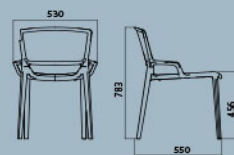

—
THE IDEAL CHAIR FOR CONTRACT USE,
AS WELL AS FOR OUTDOOR AREAS AND
OPEN-AIR SETTINGS. WITH ITS PARTI-
CULAR LOOK, FIORELLINA IS PERFECT
ALSO FOR RESIDENTIAL SPACES.





FIORELLINA
FULL



FIORELLINA PERFORATED SEAT AND BACK

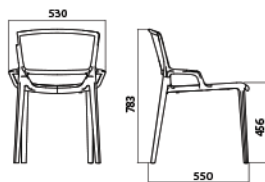

FIORELLINA PERFORATED SEAT AND BACK WITH ARMS

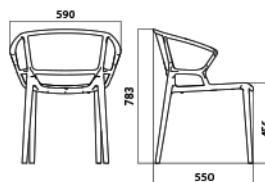

FIORELLINA FULL SEAT AND BACK

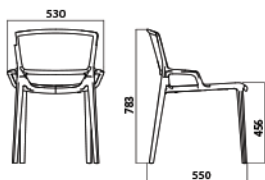

FIORELLINA FULL SEAT AND BACK WITH ARMS

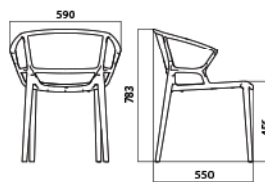

POLIPROPILENE
Polypropylene



PP20
Bianco
White



PP11
Antracite
Anthracite



PP1023
Giallo mais
Corn yellow



PP514
Sabbia
Sand



PP3020
Rosso
Red

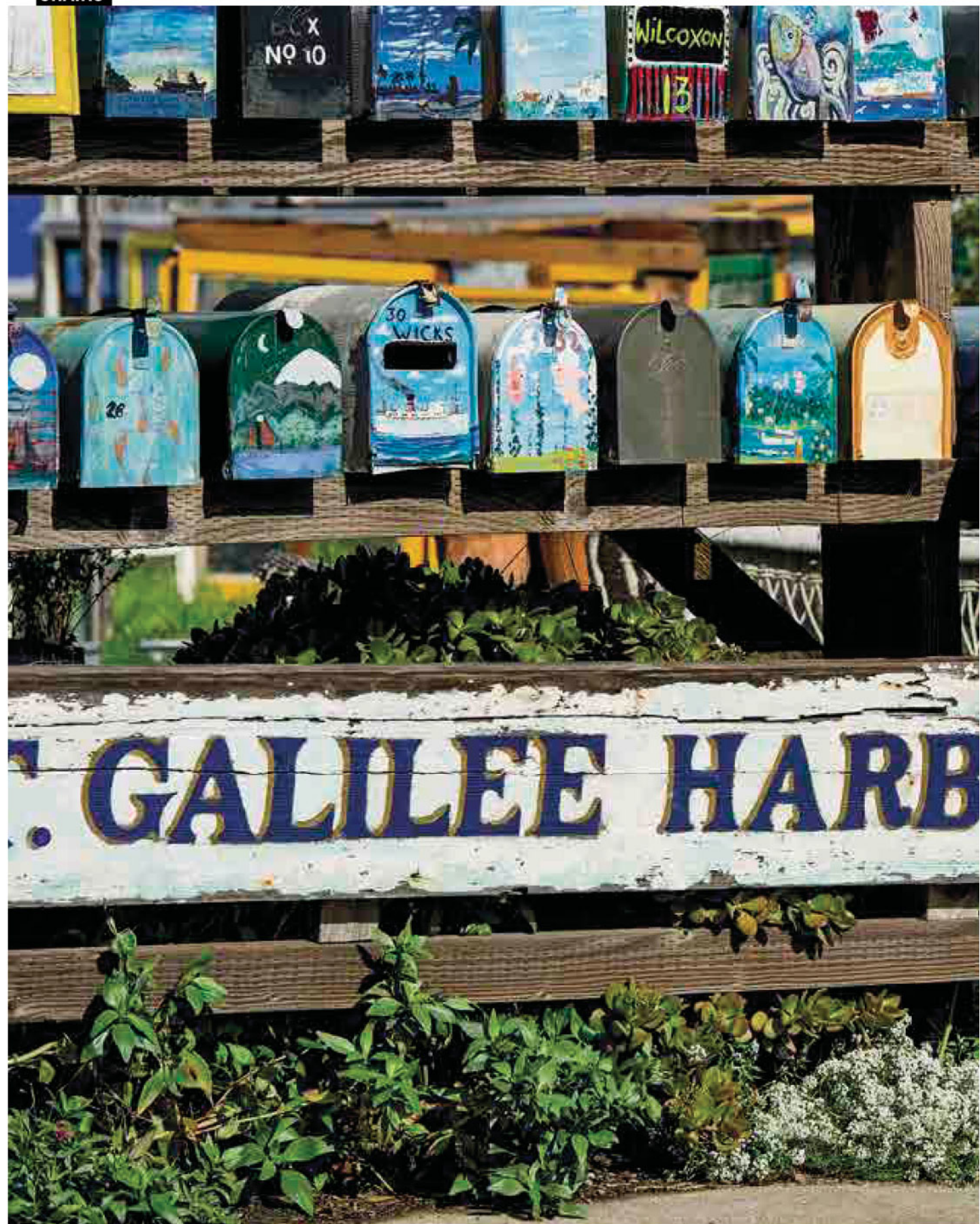



SIDNEY

—

ONE OF THE MOST MULTI-CULTURAL CITIES IN THE WORLD, OVERLOOKING A BAY WHERE NATURE IS AT ITS BEST IN TERMS OF BEAUTY AND CLIMATE. THE IDEAL DESTINATION FOR SURFERS FROM ALL OVER THE WORLD AND POPULATED BY SOME OF THE STRANGEST, AND MOST DANGEROUS ANIMALS ON THE PLANET.



GPS

Latitude N 33° 52' 2"
Longitude E 151° 12' 25"







DROP

Awarded the Good Design Award in 2011, Drop is a chair for contract settings, with a playful design and in a wide range of colours. The ideal synthesis of the dynamic and essential style of the Infiniti collection.



DROP

DESIGN:
ORLANDINI&RADICE

—
ONE-PIECE GLASS-FIBRE REIN-
FORCED POLYPROPYLENE
CHAIR. STACKABLE. PERFECTLY
SUITABLE FOR OUTDOOR USE.
THE SEAT FEATURES A CENTRAL
HOLE FACILITATING RAINWATER
DRAINAGE.

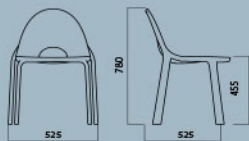

— IT LENDS CHEERFULNESS AND IRONY TO PUBLIC SPACES LIKE BARS, PUBS, AND RESTAURANTS. TOTALLY RECYCLABLE DESIGN PRODUCT.

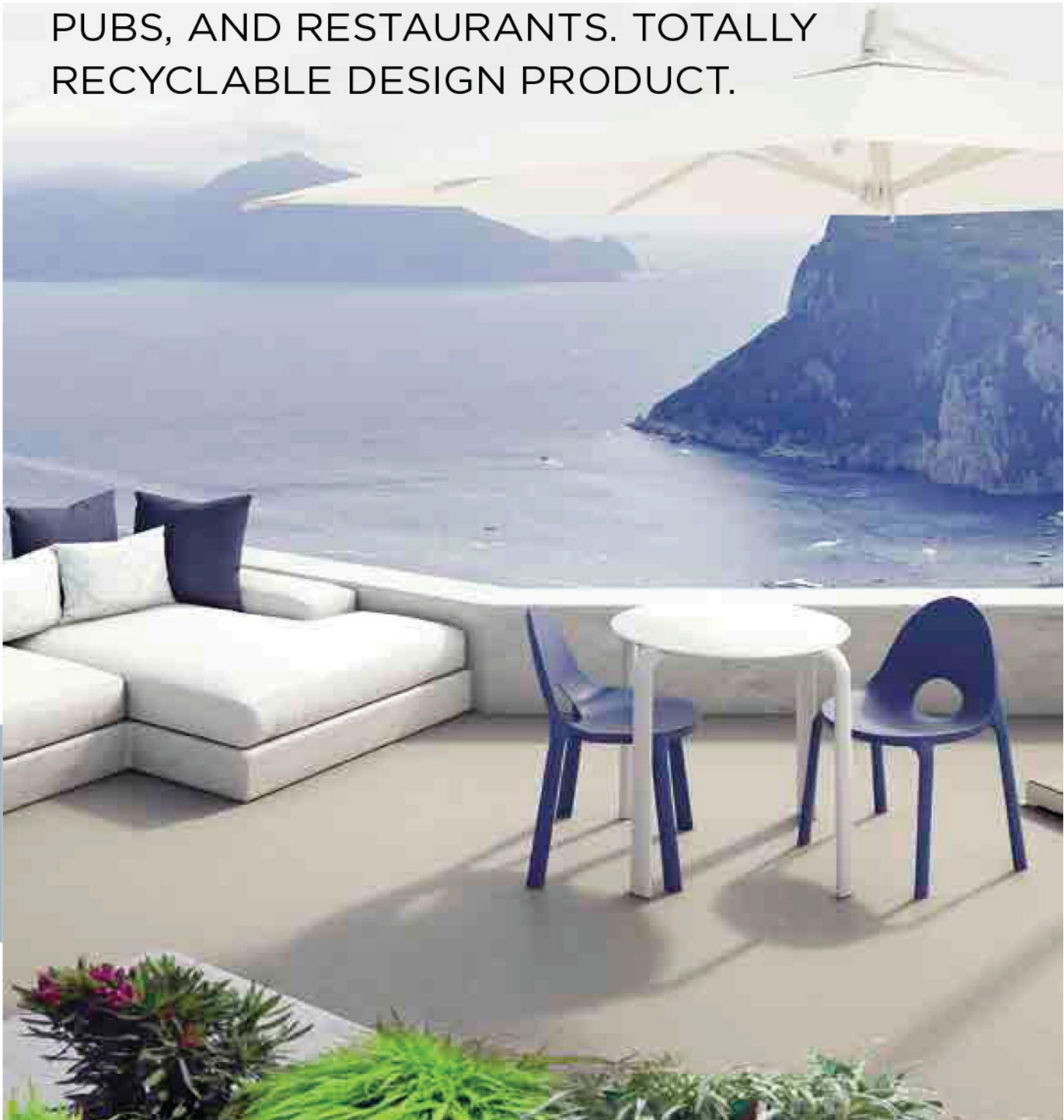

DROP CHAIR

RIVESTIMENTO
Upholstery

IMPILABILITÀ
Stackability

ESTERNO
Outdoor

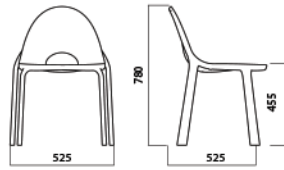

POLIPROPILENE

Polypropylene



PP20
Bianco
White



PP1016
Giallo limone
Lemon yellow



PP514
Sabbia
Sand



PP02
Arancione
Orange



PP3020
Rosso
Red



PP6018
Verde tropicale
Tropical green



PP4001
Viola
Purple



PP5019
Blu Capri
Capri Blue

CHAIRS









MARGOT

Moulded in polycarbonate, it stylishly decorates not only home and domestic settings but also the largest restaurant areas. The versions in transparent or opaque colours make it a very versatile seat.



MARGOT

DESIGN:
CROSERÀ SPADACCIO

—
MANUFACTURED THROUGH A
SPECIFIC GAS-ASSIST INJECTION
MOULDING SYSTEM. STACKABLE.
SUPPLIED WITH RUBBER FOOT.

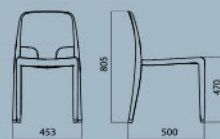



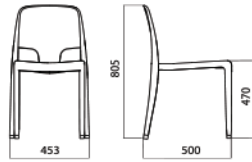

POLICARBONATO TRASPARENTE

Transparent polycarbonate



PC103
Ghiaccio
Ice



PC104
Fumé
Smoke-grey



PC123
Vinaccia
Burgundy



PC111
Ambra
Amber

POLICARBONATO COPRENTE

Solid colour polycarbonate



PC101
Bianco
White



PC102
Nero
Black







G-CHAIR

Its distinctive feature is the original frame design which is inspired by the letter "G". An original idea for furnishing hotel rooms and lounge areas with character.





G-CHAIR

DESIGN:
JAKOB THAU

COLD-FOAMED POLYURETHANE
SEAT AND BACKREST, EITHER
PAINTED OR UPHOLSTERED. POLI-
SHED ALUMINIUM FRAME.

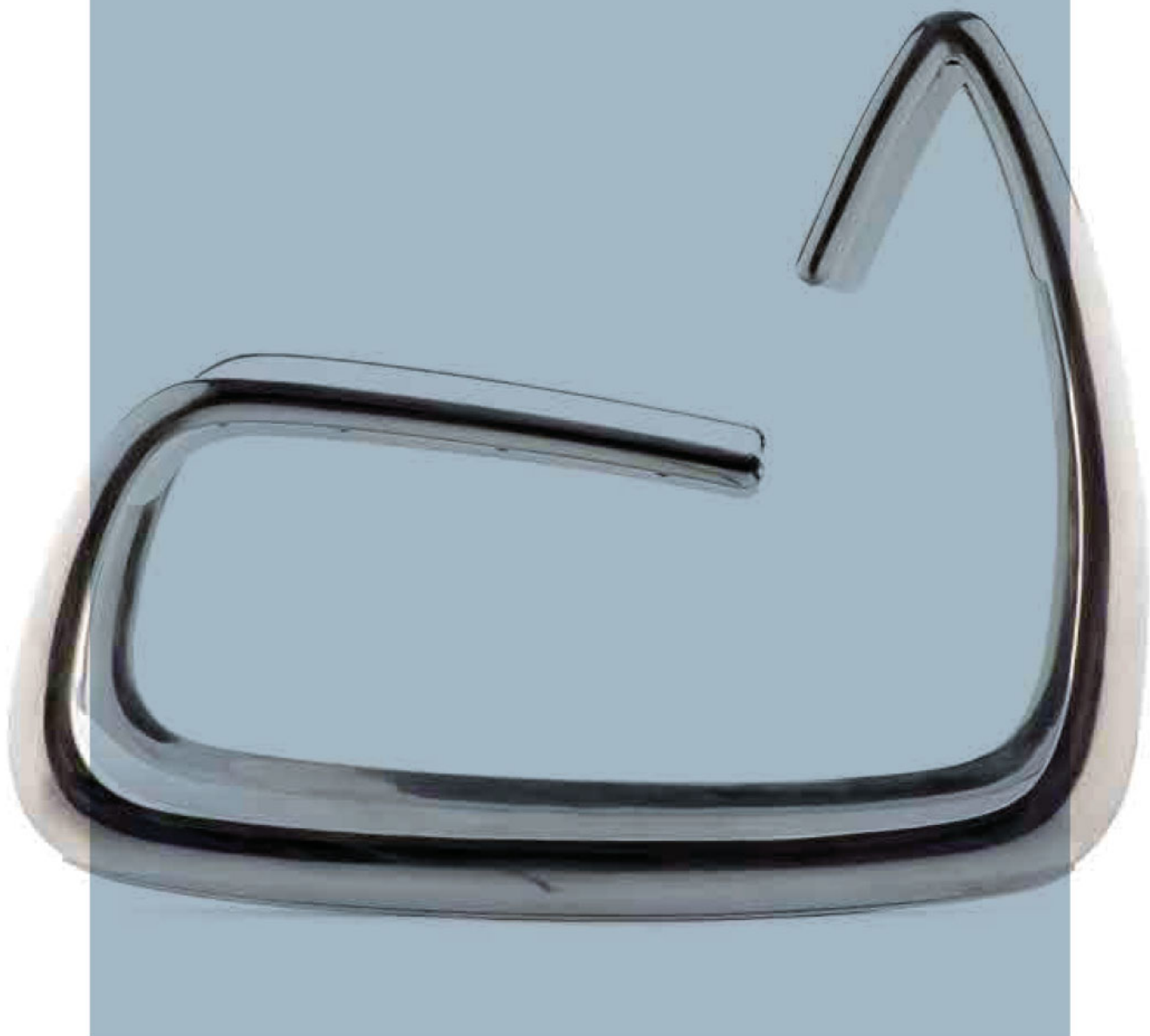
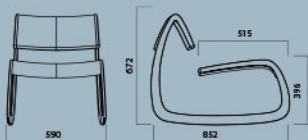



G-CHAIR

RIVESTIMENTO
Upholstery

IMPILABILITÀ
Stackability

ESTERNO
Outdoor

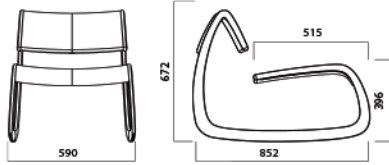

G-CHAIR OUTDOOR

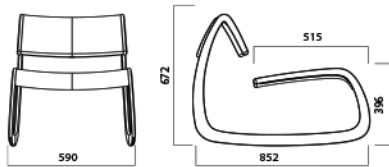

*G-Chair Outdoor con rivestimento Kirkby Design
G-Chair Outdoor upholstered with Kirkby Design fabric*

TELAIO/Frame

TELAIO IN ALLUMINIO

Steel frame



AL07
Pulito
Polished



AL30
Verniciato bianco opaco
White matt painted



AL31
Verniciato opaco nero
Black matt painted

SCHIENALE/Backrest

POLIURETANO COLORATO

Colour polyurethane



PU02
Bianco
White



PU03
Nero
Black



PU01
Rosso
Red

TAPPEZZERIA

Upholstery

*Canvas Kvadrat
Cava 3 Kvadrat
Divina 3 Kvadrat*

*Divina Melange 2
Kvadrat
Outback Kvadrat*

*Field Kvadrat
Umami Kvadrat
Flash No-shrink*

*Byte
Kirkby Design*

TOKYO

—

AN EXTRAORDINARY MEGALOPOLIS, WITH A POPULATION THAT IS SECOND ONLY TO BEIJING. CULTURE AND ANCIENT TRADITIONS COEXIST WITH THE MOST FUTURISTIC URBAN SOLUTIONS: THE MAGIC AND THE RATIONALISM OF THE EAST ARE WOVEN TOGETHER TO CREATE A UNIQUE AND UNMATCHED FABRIC.



GPS

Latitude N 35° 41' 22"
Longitude E 139° 41' 30"







CALLITA CHAIR

One of Infniti's classics: Callita is a low chair with a design that recalls the sinuous forms of the ideograms of Japanese calligraphy. Reference to an ancient art for a product with a modern and minimalist style.



CALLITA

DESIGN:
ANDREAS OSTWALD

RIGID PAINTED POLYURETHANE
LOW CHAIR RESTING ON A DIE-
CAST ALUMINIUM FIXED BASE.
WIDE ENVELOPING BACKREST.





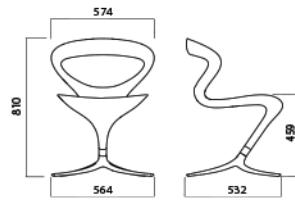

POLIURETANO COLORATO

Colour polyurethane



PU02
Bianco
White



PU03
Nero
Black



PU01
Rosso
Red

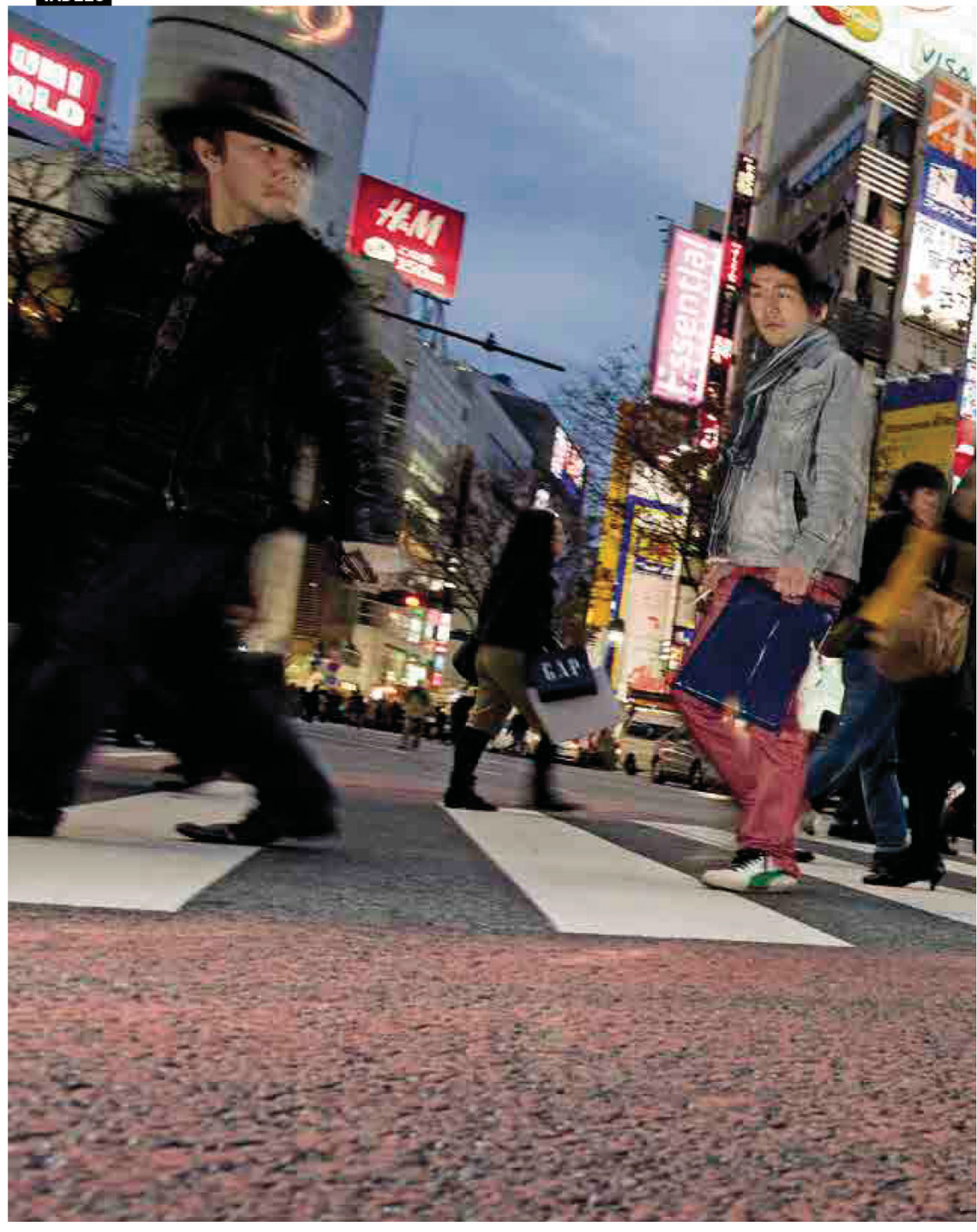







COOKIE

An intriguing, sinuous, and essential design. Cookie is an elegant and comfortable low chair, made up of a polycarbonate shell which can be fitted with two different bases: a swivel aluminium base or wooden leg base.



COOKIE

DESIGN:
STUDIO ZETASS

—
OPAQUE OR TRANSPARENT
POLYCARBONATE SHELL ON A
SWIVEL BASE LACQUERED IN THE
SAME COLOUR AS THE SHELL.

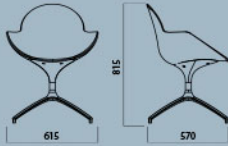

—
A CHAIR WITH A UNIQUE CHARACTER: A
TRUE PROTAGONIST IN REFINED LOUNGE
SETTINGS OR COMFORTABLE WAITING
AREAS.



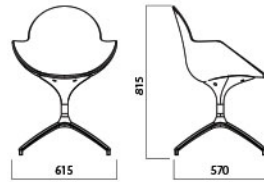

COOKIE SWIVEL

RIVESTIMENTO
UpholsteryIMPILABILITÀ
StackabilityESTERNO
Outdoor

COOKIE WOODEN LEGS

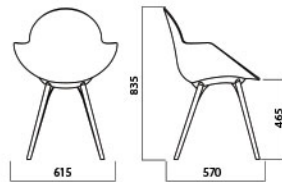

TELAIO IN MASSELLO DI FAGGIO



Solid beech

MAFGV
Faggio naturale
Natural beech

POLICARBONATO TRASPARENTE



Transparent polycarbonate

PC103
Ghiaccio
Ice

TELAIO MASSELLO DI FAGGIO LACCATO

Lacquered solid beech frame



MAFLG6
Faggio laccato
bianco
White lacquered
beech



MAF02
Faggio laccato
nero
Black lacquered
beech



MAF03
Faggio laccato
rosso
Red lacquered
beech



MAF01
Faggio laccato grigio
siliceo
Silica grey lacquered
beech

SCocca IN POLICARBONATO COPRENTE

Solid colour polycarbonate

N.B. Gambe laccate nello stesso colore della scocca
N.b. Lacquered legs in the same colour as the shell



PC101
Bianco
White



PC102
Nero
Black



PC114
Rosso
Red



PC117
Grigio siliceo
Silica grey

BASE A 4 RAZZE IN ALLUMINIO PULITO LUCIDO

Die-cast polished aluminium 4 star base



AL07
Pulito
Polished

POLICARBONATO

Polycarbonate



PC117
Grigio siliceo
Silica grey



PC103
Ghiaccio
Ice

BASE A 4 RAZZE IN ALLUMINIO VERNICIATO

Painted aluminium 4-star base



AL04
Verniciato bianco
lucido
Polished white
painted



AL05
Verniciato nero
lucido
Polished black
painted



AL08
Verniciato rosso
Red painted

SCocca IN POLICARBONATO COPRENTE

Solid colour polycarbonate

N.B. Base verniciata nello stesso colore della scocca
N.b. Base painted matching shell colour



PC101
Bianco
White



PC102
Nero
Black



PC114
Rosso
Red

TAPPEZZERIA

Upholstery

Canvas Kvadrat
Cava 3 Kvadrat
Divina 3 Kvadrat

Divina Melange 2
Kvadrat
Outback Kvadrat

Field Kvadrat
Umami Kvadrat

Flash No-shrink
Byte

PELLE FIORE

Full-grain leather

ECOPELLE

Eco leather









WEB

Functionality and essentiality for this chair with chromium-plated or painted sled base. The seat and backrest can be covered in leather, eco-leather or fabric.



WEB

DESIGN:
GIANCARLO BISAGLIA

SPECIFICALLY DESIGNED TO BE
HIGHLY STACKABLE, IT IS THE
PERFECT SOLUTION TO DECORA-
TE PUBLIC SPACES, CONFERENCE
ROOMS OR CONCERT HALLS.

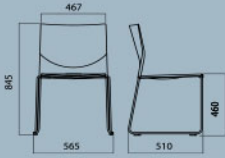



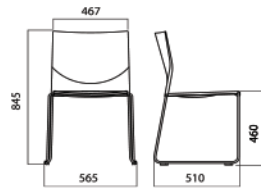

TELAIO/Frame

TELAIO IN ACCIAIO

Steel frame



AC01
Cromato
Cromium-plated



AC30
Verniciato bianco
opaco
White matt painted



AC31
Verniciato nero
opaco
Black matt painted



AC32
Verniciato grigio
opaco
Grey matt painted

TAPPEZZERIA

Upholstery

Canvas Kvadrat
Cava 3 Kvadrat
Divina 3 Kvadrat

Divina Melange 2
Kvadrat
Outback Kvadrat

Field Kvadrat
Umami Kvadrat

Flash No-shrink
Byte

PELLE FIORE

Full-grain leather

ECOPELLE

Eco leather





GIULITTA

Fully upholstered four-leg chair,
Giulitta is ideal for colourful,
"pop" settings.



GIULITTA

DESIGN:
PIERVITTORIO PREVEDELLO

—
COLD-FOAMED POLYURETHANE
CHAIR ENTIRELY UPHOLSTERED
IN FABRIC.

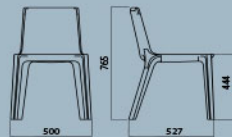



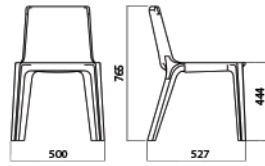

TAPPEZZERIA

Upholstery

Canvas Kvadrat
Cava 3 Kvadrat
Divina 3 Kvadrat

Divina Melange 2
Kvadrat
Outback Kvadrat

Field Kvadrat
Umami Kvadrat

Flash No-shrink
Byte

PELLE FIORE

Full-grain leather

ECOPELLE

Eco leather





LISBON

—

LISBON IS THE CLASSIC COASTAL CITY WITH AN OLD-WORLD CHARM, WHERE PAGES OF HISTORY AND LITERATURE, WRITTEN IN BOOKS THAT TELL OF EXPLORERS AND FISHERMEN, INTERTWINE. A WONDERFUL MOSAIC OF CULTURE AND NATURE IS THE BACKDROP TO THE MELODIC MUSIC OF THE FADO.

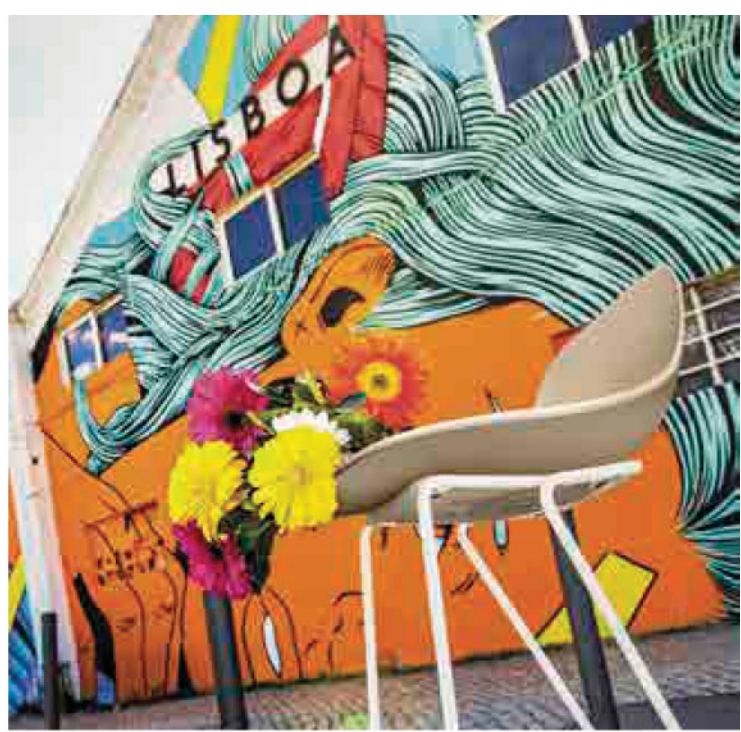

GPS

Latitude N 38° 43' 20"
Longitude E 9° 8' 21"





ARKUA

A comfortable and practical folding chair, supplied on request with a trolley for transporting ten chairs.





ARKUA

DESIGN:
GIANCARLO BISAGLIA

—
POLYPROPYLENE SEAT AND
BACKREST, PAINTED EMBOSSED
STEEL LEGS IN THE SAME CO-
LOUR AS THE PLASTIC.





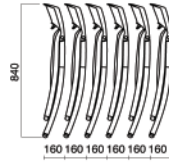
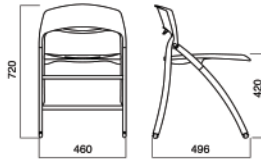

TELAIO ACCIAIO VERNICIATO GOFFRATO

Embossed painted steel frame



AC20
Bianco
White



AC07
Grigio
Grey



AC1016
Giallo
Yellow



AC514
Sabbia
Sand



AC3020
Rosso
Red

POLIPROPILENE CARICATO FIBRA DI VETRO

Polypropylene and fibreglass



PP20
Bianco
White



PP07
Grigio cemento
Cement grey



PP1016
Giallo limone
Lemon yellow



PP514
Sabbia
Sand



PP3020
Rosso
Red

N.B. Base verniciata nello stesso colore della scocca
N.b. Base painted matching shell colour

N.B. Gambe laccate nello stesso colore della scocca
N.b. Lacquered legs in the same colour as the shell





HUG

A chair that is as comfortable as a hug. The combination of wood and fabric, in rigorous geometric shapes, contribute to creating an extremely elegant chair, with a strong Scandinavian inspiration and several different base versions and shell sizes.

**HUG**DESIGN:
MARCELLO ZILIANI

ASH PLYWOOD SHELL MADE UP OF TWO SYMMETRICAL ELEMENTS CONNECTED BY AN ALUMINIUM JOINT. STURDY SLED BASE MADE OF RECTANGULAR-SECTION STEEL TUBING.

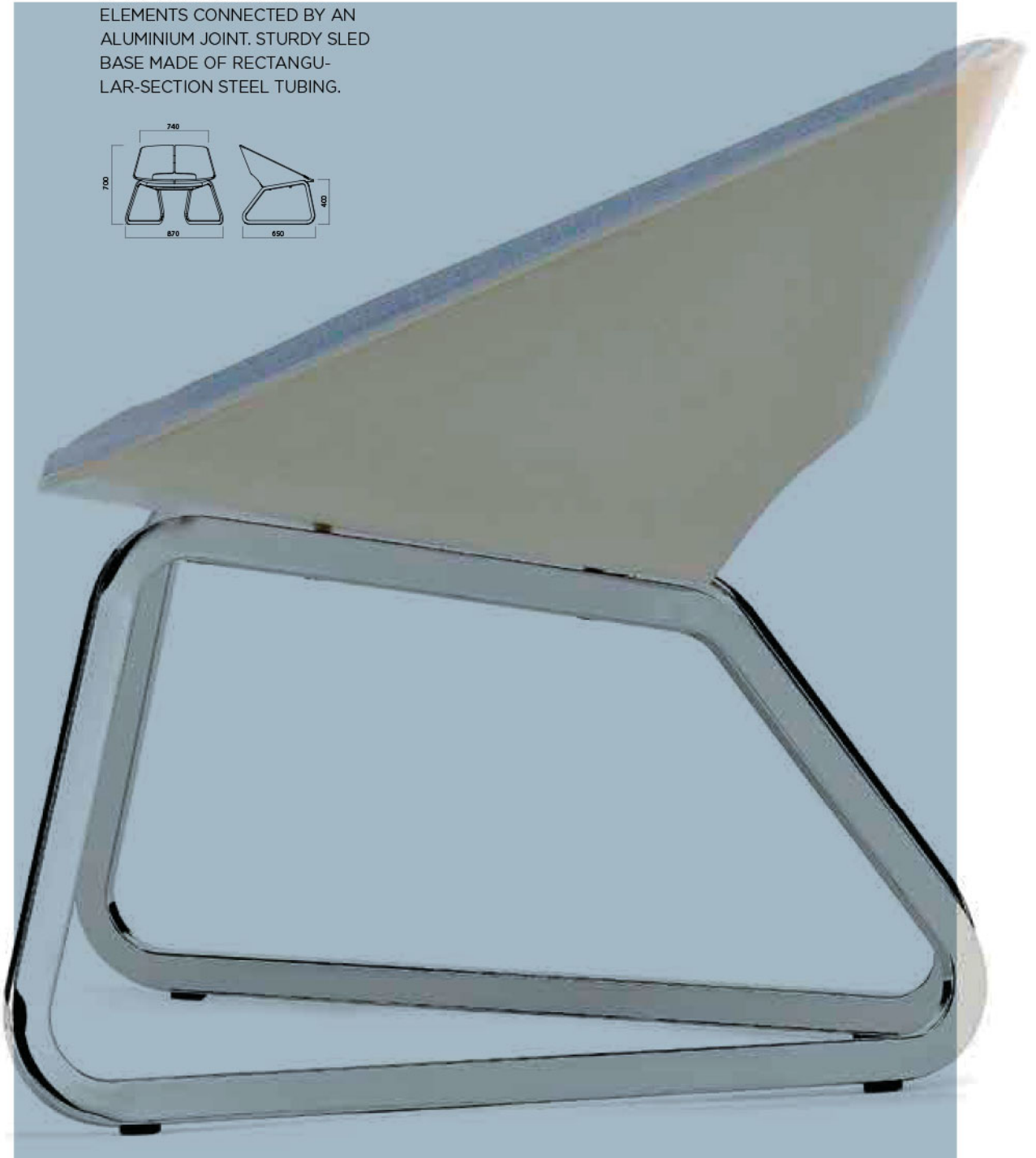
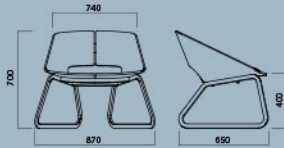

— THE RATIONAL SLEEK WOODEN SILHOUETTE IS SUITABLE FOR MINIMALIST MODERN SPACES. THE VERSION WITH A SMALLER SHELL IS PERFECT FOR WAITING ROOMS AND READING AREAS. AN EXCELLENT SOLUTION FOR YOUR LIVING AREA IN THE SOFA VERSION.





HUG
SOFA



HUG
MAXI SWIVEL

RIVESTIMENTO
UpholsteryIMPILABILITÀ
StackabilityESTERNO
Outdoor

HUG SWIVEL ALUMINIUM BASE

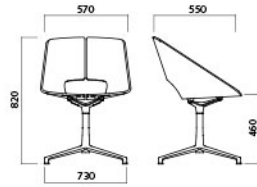

HUG SWIVEL WOODEN BASE

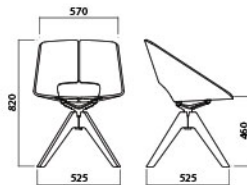

HUG SLEDGE

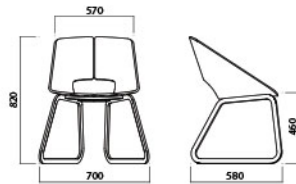

HUG MAXI SWIVEL ALUMINIUM BASE

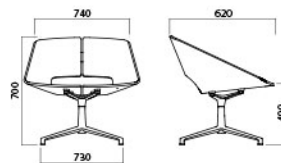

HUG MAXI SWIVEL WOODEN BASE

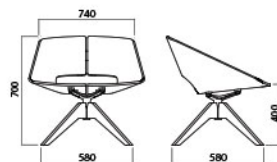

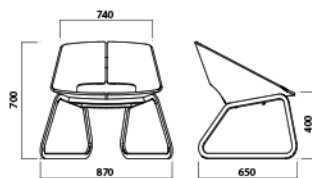

HOG SOFA

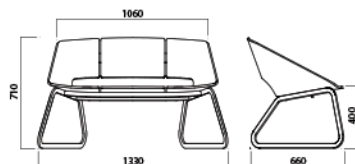

TELAIO/Frame

TELAIO IN ACCIAIO

Steel frame



AC01
Cromato
Cromlum-plated



AC30
Verniciato bianco
opaco
White matt painted



AC31
Verniciato nero
opaco
Black matt painted

BASE GIREVOLE IN ALLUMINIO

Steel frame

N.B. Base in frassino girevole nello stesso colore della scocca
N.b. Base painted matching shell colour



AL07
Pulito
Polished



AL30
Verniciato bianco
opaco
White matt painted



AL31
Verniciato opaco
nero
Black matt painted

SCOCCA/Shell

MULTISTRATO DI FRASSINO

Solid ash



LFR01
Frassino sbiancato
Whitened ash



LFR02
Frassino wengé
Wenge-stain ash



LFR03
Frassino naturale
Natural ash



LFR04
Frassino verniciato
ocra
Rovre Verniciato ash



LFR05
Frassino verniciato
bordeaux
Bordeaux painted
ash



LFR06
Frassino verniciato
antracite
Anthracite painted
ash



LFR07
Frassino verniciato
verde
Green painted ash



LFR08
Frassino verniciato
nero
Black painted ash

TAPPEZZERIA

Upholstery

Canvas Kvadrat
Cava 3 Kvadrat
Divina 3 Kvadrat

Divina Melange 2
Kvadrat
Outback Kvadrat

Field Kvadrat
Umami 3 Kvadrat

Flash No-shrink
Byte

PELLE FIORE

Full-grain leather

ECOPELLE

Eco leather







CHARLOTTE

A comfortable low swivel chair with arms integrated into its sinuous silhouette. The wood shell and aluminium base are available with several paintings.





CHARLOTTE

DESIGN:
INFINITI DESIGNERS

—
INTERNALLY COVERED ASH
PLYWOOD SHELL. ALUMINIUM
SWIVEL BASE.





CHARLOTTE

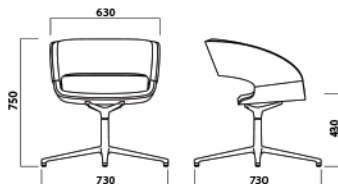

BASE/Base

BASE IN ALLUMINIO

Aluminium base



AL07
Polito
Polished



AL30
Verniciato bianco opaco
White matt painted



AL31
Verniciato opaco nero
Black matt painted

SCocca/Shell

LEGNO MULTISTRATO 3D

3D Plywood



LFR01
Frassino sbiancato
Whitened ash



LFR02
Frassino wengè
Wenge-stain ash



LFR03
Frassino naturale
Natural ash



LFR04
Frassino verniciato ocre
Ochre painted ash



LFR05
Frassino verniciato bordeaux
Bordeaux painted ash



LFR06
Frassino verniciato antracite
Anthracite painted ash



LFR07
Frassino verniciato verde
Green painted ash



LFR08
Frassino verniciato nero
Black painted ash

TAPPEZZERIA

Upholstery

Canvas Kvadrat
Cava 3 Kvadrat
Divina 3 Kvadrat

Divina Melange 2 Kvadrat
Outback Kvadrat

Feld Kvadrat
Umami Kvadrat

Flash No-shrink
Byte

PELLE FIORE
Full-grain leather

ECOPELLE

Eco leather





PIN UP

One of the most iconic products in the entire collection, inspired by the sensuality of the 1950s pin-ups. Available in polyurethane or with upholstery for improved comfort.



PIN UP

DESIGN:
STUDIO ZETASS

—
FREEFORM INTEGRAL POLYURETHANE LOW CHAIR WITH POLISHED STEEL SWIVEL BASE.

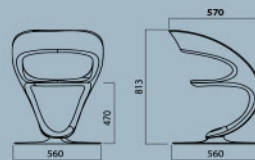



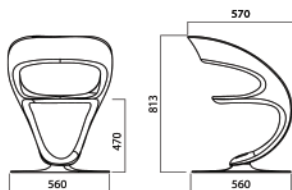

BASE/Base

BASE IN ACCIAIO

Steel base



AC01
Cromato
Cromium-plated

POLIURETANO
COLORATO



Colour polyurethane

PU20
Bianco
White

PU12
Avorio
Ivory

PU11
Antracite
Anthracite

PU06
Verde mela
Green app

PU01
Rosso
Red

PU10
Caffè
Coffee

TAPPEZZERIA

Upholstery

Canvas Kvadrat
Cava 3 Kvadrat
Divina 3 Kvadrat

Divina Melange 2
Kvadrat
Outback Kvadrat

Field Kvadrat
Umami Kvadrat

Flash No-shrink
Byte

PELLE FIORE

Full-grain leather

ECOPELLE

Eco leather





BEETLE

Lines that are simple as they are enveloping: a low lounge chair created with a high or low backrest and paired with a comfortable pouf. Covers in leather, eco-leather or fabric.



BEETLE

DESIGN:
GIANCARLO BISAGLIA

COLD-FOAMED POLYURETHANE ARMCHAIR UPHOLSTERED IN FABRIC. FOUR-STAR ALUMINIUM SWIVEL BASE IN THE LOW BACKREST VERSION.

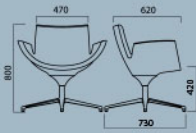



BEETLE
LOW BACK

—
FEATURING A FRESH ELEGANT DESIGN, BEETLE DECORATES WITH CHARACTER THE WAITING AREAS AND HOTEL LOUNGES ALL OVER THE WORLD.

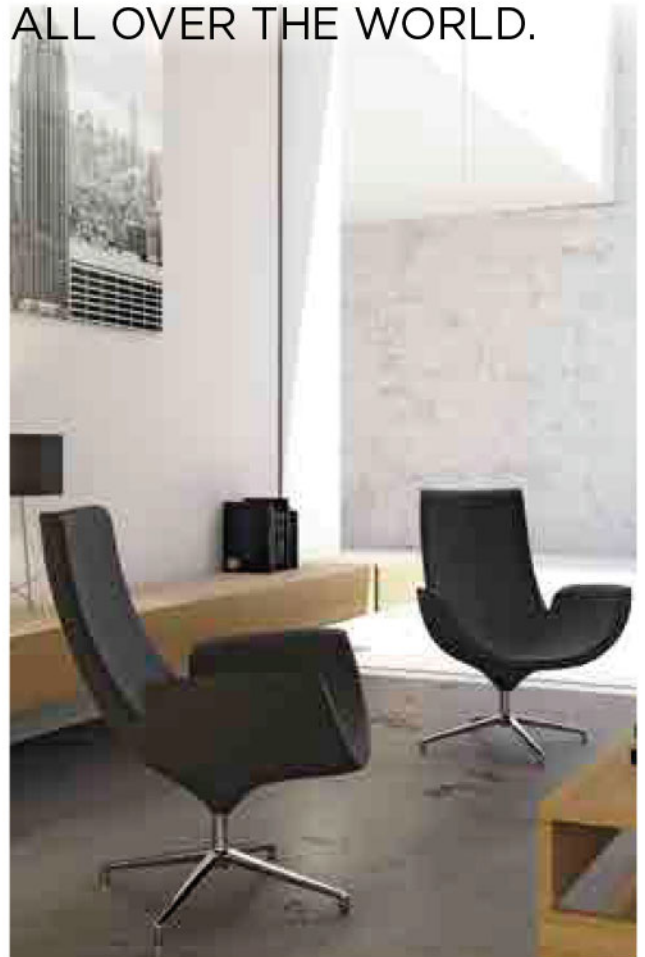

BETLE HIGH BACK

RIVESTIMENTO
Upholstery

IMPILABILITÀ
Stackability

ESTERNO
Outdoor

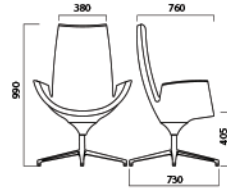

BETLE LOW BACK

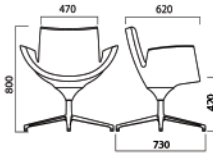

BETLE POUFF

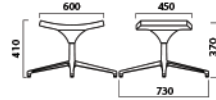

BASE/Base

BASE IN ALLUMINIO

Aluminium base



AL07
Pulito
Polished



AL30
Verniciato bianco
opaco
White matt painted



AL31
Verniciato opaco
nero
Black matt painted

TAPPEZZERIA

Upholstery

Canvas Kvadrat
Cava 3 Kvadrat
Divina 3 Kvadrat

Divina Melange 2
Kvadrat
Outback Kvadrat

Field Kvadrat
Umami Kvadrat

Flash No-shrink
Byte

PELLE FIORE

Full-grain leather

ECOPELLE

Eco leather





BRONCIO

A product family for outdoor use, manufactured in rotational-moulded plastic and made up of a stool in two different heights and a table. The low stool has a comfortable opening seat, while the higher stool and the table can be equipped with a lighting kit.

—
BRONCIO IS A FURNISHING ACCESSORY THAT BLENDS PERFECTLY WITH ANY OUTDOOR ENVIRONMENT OR WELLNESS AREA THANKS TO ITS VERSATILITY IN OPEN-AIR SETTINGS AND THE POSSIBILITY TO BE EQUIPPED WITH LIGHTING.



BRONCIO
STOOL - TABLE



BRONCIO
STOOL - TABLE

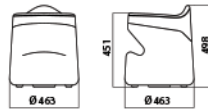

BRONCIO HIGH STOOL

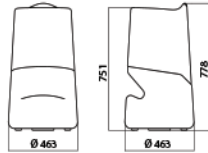

BRONCIO TABLE

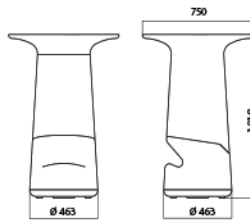

BASE/Base

POLIETILENE

Polyethylene



PE300/PE301
Blanco/Giallo
White/Yellow

PE300/PE303
Blanco/Verde
White/Green

PE300/PE302
Blanco/Grigio
White/Grey

PE300/PE300
Blanco/Bianco
White/White

PE304/PE304
Neutro/Neutro
Neutral/Neutral

Disponibile per la versione con kit di illuminazione, solo su Broncio High Stool e Broncio Table
Available for lighting kit version into Broncio High Stool and Broncio Table only



ZED STOOL

ZED STOOL

A stool with a curvy, fun silhouette. Conceived as a furnishing accessory for restaurants, pubs and hotel lounge areas.





ZED STOOL

DESIGN:
INFINITI DESIGNERS

ZED STOOL

—
POLYURETHANE SWIVEL STOOL
WITH GAS SEAT HEIGHT ADJUST-
MENT. CHROMIUM-PLATED STEEL
BASE AND FOOTREST.

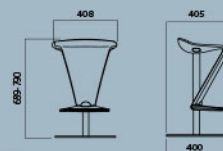
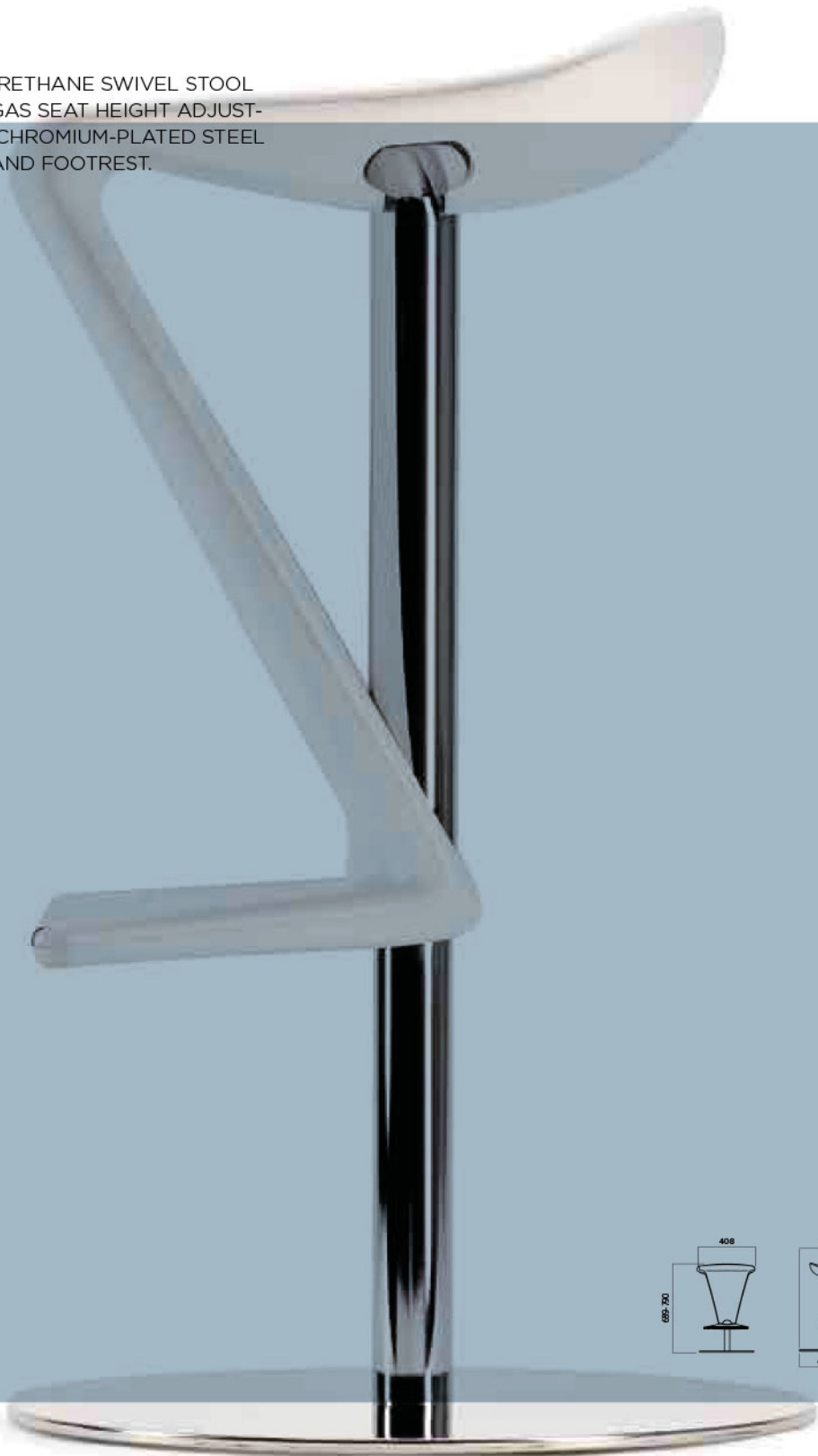



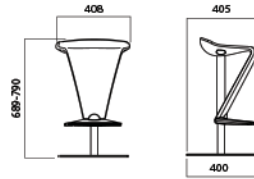

BASE/Base

BASE IN ACCIAIO

Steel base



AC01
Cromato
Cromium-plated



AC20
Verniciato goffrato
bianco
White embossed
painted



AC31
Verniciato nero
opaco
Black matt painted

POLIURETANO COLORATO

Colour polyurethane



PU20
Bianco
White



PU04
Argento
Silver



PU03
Nero
Black



PU16
Pistacchio
Pistachio



PU05
Viola
Purple



PU01
Rosso
Red

SAN FRANCISCO

—

ONE OF THE MOST BEAUTIFUL CITIES IN CALIFORNIA: IT IS A PLEASURE TO LOSE YOURSELF IN ITS STEEP HILLS, IN THE COOL SUMMER MISTS. THE VICTORIAN STYLE AND THE MODERN ARCHITECTURE GENERATE SCENIC SHORT CIRCUITS: THE GOLDEN GATE BRIDGE, THE TRAMS AND CHINATOWN OFFER THE PERFECT BACKDROP TO GREAT CULTURAL VITALITY

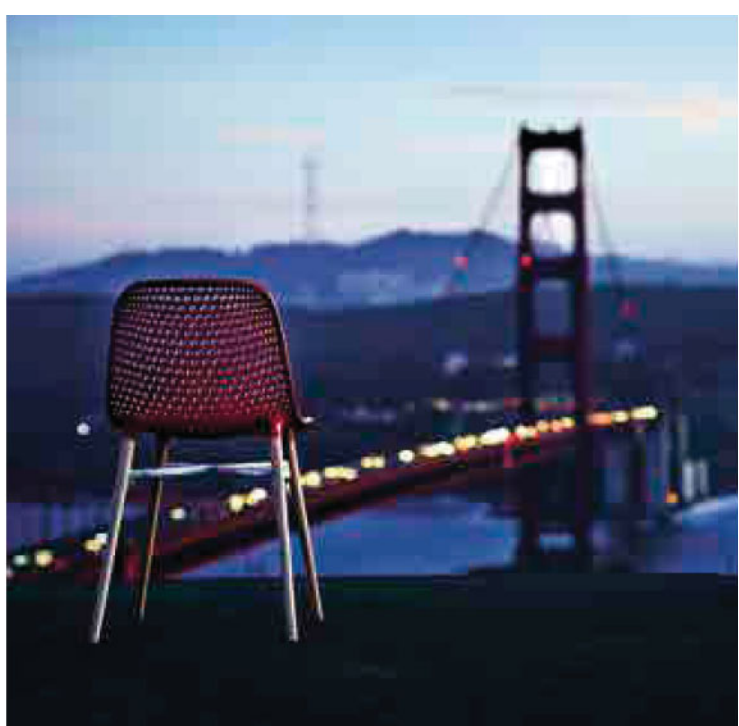

GPS

Latitude N 37° 46' 29"
Longitude E 122° 25' 9"

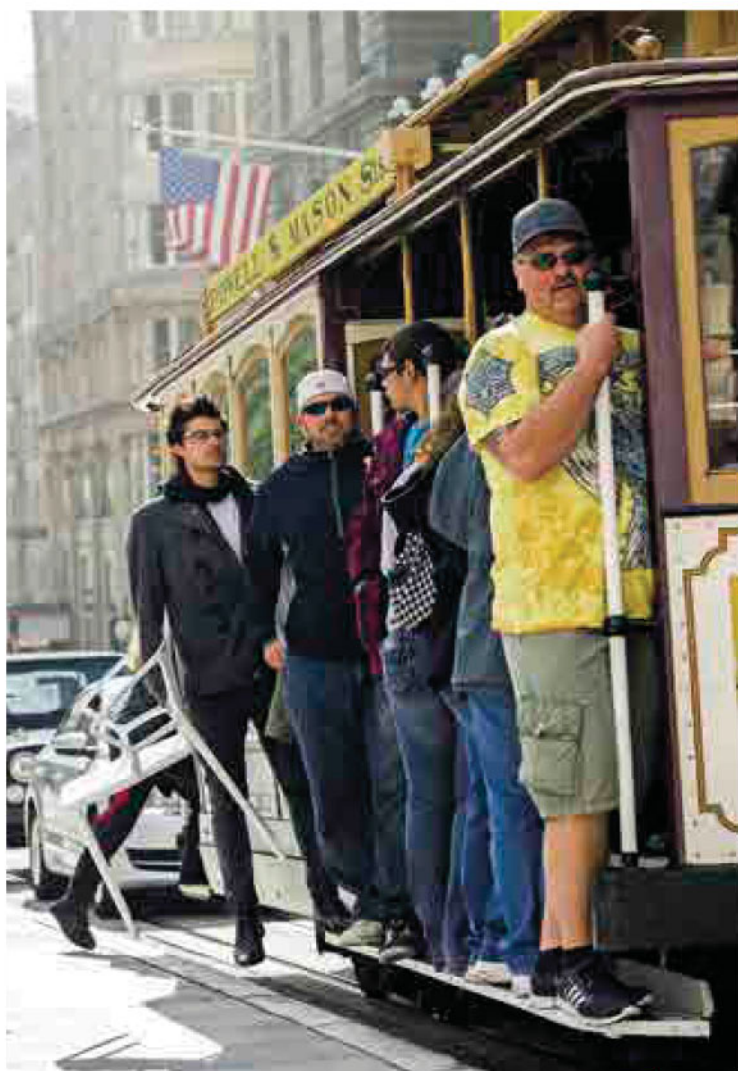





PICAPAU STOOL

Practical and lightweight, it is available in 3 different heights. The numerous colour combinations of the natural or lacquered wooden frame and the plastic seat make it suitable for any situation.



PICAPAU STOOL

DESIGN:
ORLANDINI E RADICE

—
GLASS FIBRE-REINFORCED
POLYPROPYLENE SEAT. SOLID BE-
ECH WOOD BASE WITH RUBBER
FOOT. FOOTREST MADE OF STEEL
PAINTED IN THE SAME FINISH AS
THE SEAT.



—
IN ITS HIGH- AND MEDI-
UM-HEIGHT VERSIONS,
PICAPAU ENHANCES YOUR
KITCHEN BAR AREA AND
RETAIL SPACES. USED IN
ITS LOW-HEIGHT VERSION,
IT IS A FUNCTIONAL FUR-
NISHING ACCESSORY FOR
ANY TYPE OF LIVING ARE-
AS.

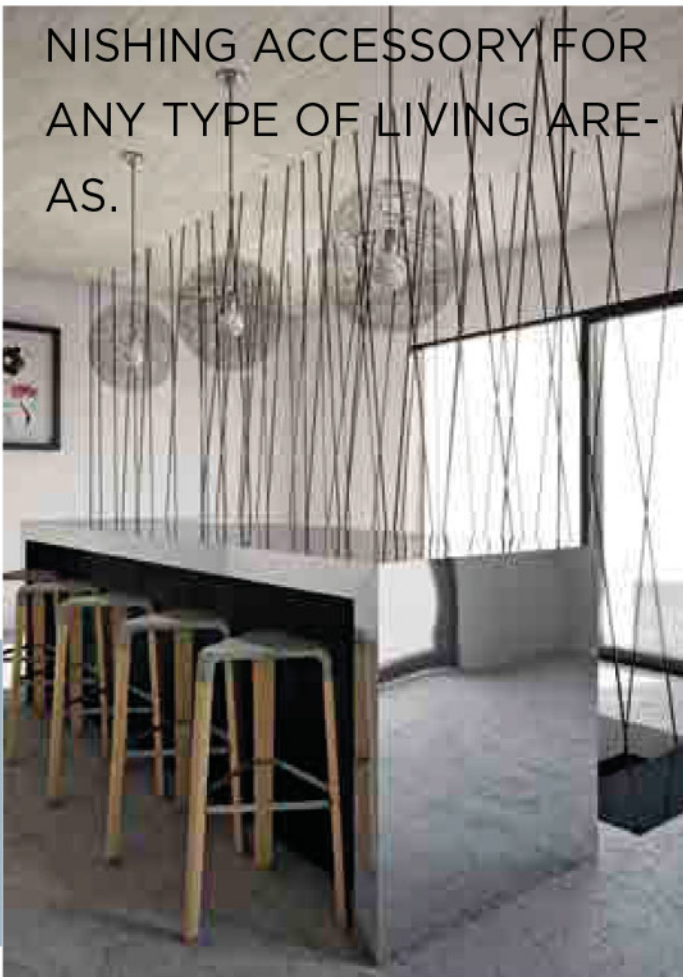

PICAPAU
KITCHEN STOOL



PICAPAU
LOW STOOL

PICAPAU LOW STOOL

RIVESTIMENTO
Upholstery

IMPILABILITÀ
Stackability

ESTERNO
Outdoor



PICAPAU KITCHEN STOOL

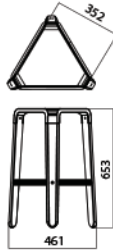

PICAPAU BAR STOOL



MASSELLO DI FAGGIO

Solid beech



MAFGV
Faggio naturale
Natural beech



MAFLG6
Faggio laccato bianco
White lacquered beech

POLIPROPILENE

Polypropylene



PP20
Bianco
White



PP7001
Grigio titanio
Titanium grey



PP1012
Senape
Mustard



PP3005
Vinaccia
Burgundy



PP513
Verde militare
Military green

CHAIRS





MOSCOW

—

ALL THE CHARM AND MYSTERY OF THE EAST FOR A METROPOLIS THAT IS THE SYMBOL OF AN IDEOLOGY. THE SIGNS OF AN OPULENT GOLDEN PAST CAN BE SEEN IN THE MOST ANCIENT ARCHITECTURES THAT COEXIST WITH THE RIGOROUS LOGIC OF THE MORE RECENT BUILDINGS. A GEM OF RARE BEAUTY CRADLED BY FREEZING TEMPERATURES AND SNOW.



GPS

Latitude N 55° 45' 20"
Longitude E 37° 37' 2"







BOBO STOOL

Bobo is a stool with a steel frame that can be chromium-plated or emboss painted in the same colour as the seat. Available in kitchen and bar height to suit all needs.



BOBO STOOL

DESIGN:
FABRIZIO BATONI

—
GLASS FIBRE-REINFORCED
POLYPROPYLENE STOOL WITH
CENTRAL HOLE. STEEL SLED
FRAME.

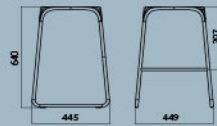

—
USED AS A COMPLEMENT IN A MODERN LIVING ROOM OR AS A FUNCTIONAL ELEMENT IN SOPHISTICATED RUSTIC INTERIORS, BOBO LENDS CHARACTER TO ANY ENVIRONMENT, COMBINING SIMPLICITY AND ERGONOMICS.

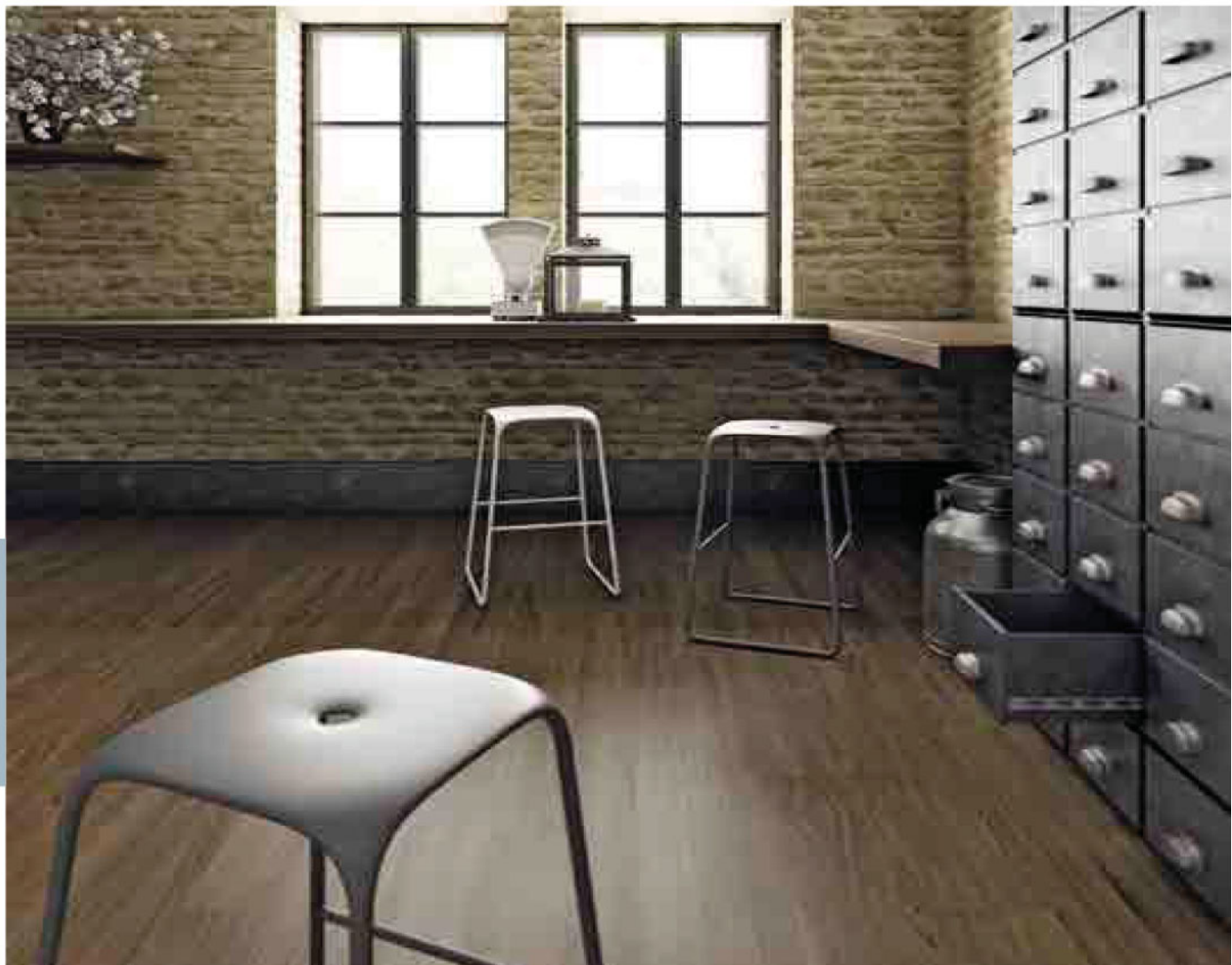

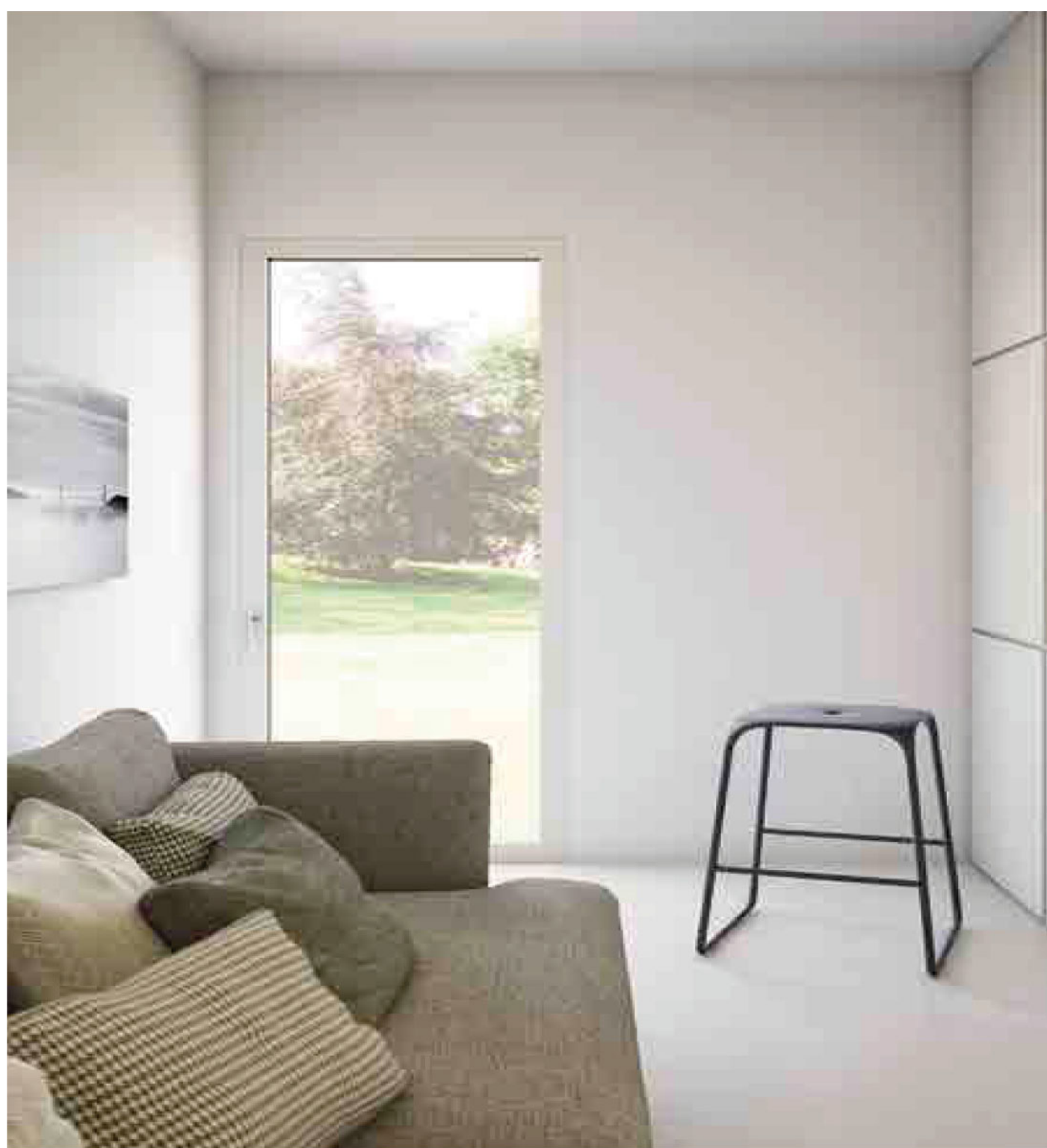

**BOBO
STOOL**



BOBO STOOL

BOBO
STOOL

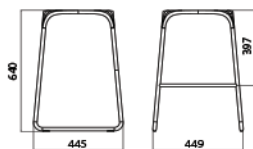

BOBO BAR STOOL

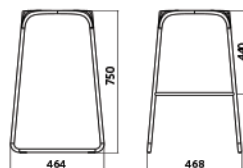

TELAIO/Frame

TELAIO IN ACCIAIO

Steel frame



AC01
Cromato
Cromium-plated



AC20
Verniciato goffrato
bianco
White embossed
painted



AC03
Verniciato goffrato
nero
Black embossed
painted

SEDUTA/Seat panel

POLIPROPILENE

Polypropylene



PP20
Bianco
White



PP11
Antracite
Anthracite



PP1016
Senape
Mustard



PP514
Sabbia
Sand



PP3020
Rosso
Red



PP512
Verde avocado
Avocado green

TELAIO/Frame

TELAIO IN ACCIAIO VERNICIATO

Steel painted frame



AC20
Bianco
White



AC11
Antracite
Anthracite



AC3020
Rosso
Red

SEDUTA/Seat panel

POLIPROPILENE

Polypropylene



PP20
Bianco
White



PP11
Antracite
Anthracite



PP3020
Rosso
Red

N.B. Gambe laccate nello stesso colore della scocca
N.b. Lacquered legs in the same colour as the shell

N.B. Base verniciata nello stesso colore della scocca
N.b. Base painted matching shell colour

ARIGATÒ



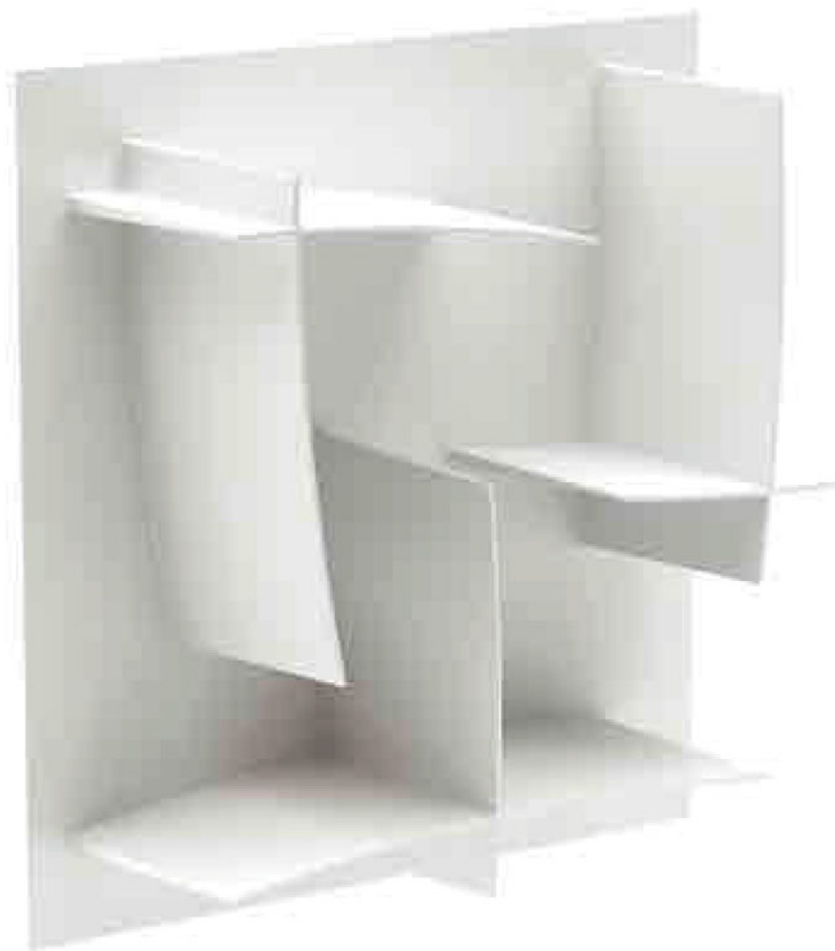

ARIGATÒ

DESIGN:
MARCELLO ZILIANI

Arigato is a furnishing accessory with minimal, functional lines. The single 65 cm square element is the ideal base for furnishing any style of wall.



Modular opaque ABS bookcase.
Available in the white, black, and red finish.

ABS

Abs



ABS
Bianco
White



ABS
Nero
Black



ABS
Rosso
Red

TABLES









DUEPERDUE

DESIGN:
BROGLIATOTRAVERSO

Essential and thin lines for the frame, paired to tops with material finishes as wood or concrete resin, are making Dueperdue table an icon of contemporary design. A perfect matching between minimalism and the warmth of authentic materials.

DUEPERDUE

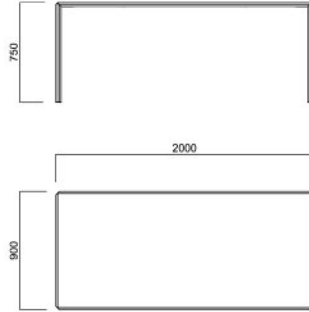

Top
2000X900mm
1600X900mm

TELAIO/Frame**BASE IN ACCIAIO**

Steel base

AC20
*Verniciato gofrato
bianco*
*White embossed
painted***AC03**
*Verniciato gofrato
nero*
*Black embossed
painted***RIPIANO/Table top****LAMINATO**

Laminates

LM01
Bianco
*White***LM02**
Nero
*Black***ROVERE HERITAGE**

Heritage oak

RH03
Naturale
*Natural***MICROTOPPING**

Microtopping

MT06
Antracite
*Anthracite***FENIX**

Fenix

FX01
Bianco
*White***FX02**
Nero
Black





NEXT TABLE

DESIGN:
ANDREAS OSTWALD

Following the Next chair characteristic tapering legs, increasing them in size to support a tabletop, Andreas Ostwald has created Next Table. With its minimal design is available in several sizes and materials.

NEXT TABLE - ROUND

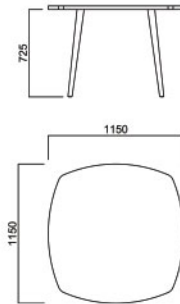

Top
1150x1150mm
1400x1400mm

NEXT TABLE - SQUARE

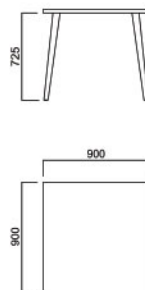

Top
800x800mm
900x900mm
1100x1100mm

NEXT TABLE - MAXI

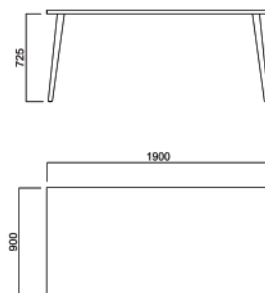

Top
1600x900mm
1900x900mm
2200x1100mm

RIPIANO/Table top

ROVERE HERITAGE



Heritage oak

RH03
Naturale
*Natural***GAMBE/Legs**

MASSELLO DI ROVERE



Solid oak

MAR03
Rovere naturale
*Natural oak***RIPIANO/Table top**

FENIX



Fenix

FX01
Bianco
*White***FX02**
Nero
*Black***GAMBE/Legs**

MASSELLO DI FAGGIO



Solid beech

MAFGV
Faggio naturale
*Natural beech***MAFLG6**
Laccato bianco
*White lacquered***MAF02**
Laccato nero
*Black lacquered***RIPIANO/Table top**

LAMINATO



Laminates

LM01
Bianco
*White***LM02**
Nero
*Black***GAMBE/Legs**

MASSELLO DI FAGGIO



Solid beech

MAFGV
Faggio naturale
*Natural beech***MAFLG6**
Laccato bianco
*White lacquered***MAF02**
Laccato nero
Black lacquered



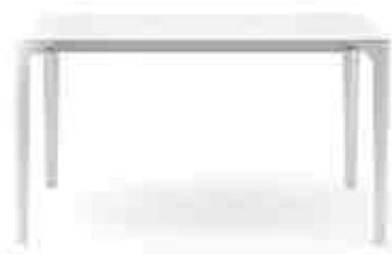

MAT

DESIGN:
PIERVITTORIO PREVEDELLO

Mat is a table with a clean, elegant design, with a Newpann top, available in oak and painted finish. Good Design Award 2013 and Red Dot Product Design 2014.

—
ESSENTIAL DESIGN AND BOLD LINES MAKE THIS TABLE THE IDEAL SOLUTION FOR SOBER ELEGANT INTERIORS.



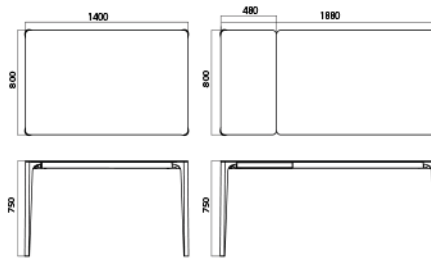

Top

800x1250mm + 480mm

800x1400mm + 480mm

900x1600mm + 580mm

TELAIO/Frame

TELAIO IN ALLUMINIO

Steel frame



AL01
Verniciato gofrato
bianco
White embossed
painted

AL03
Verniciato gofrato
antracite
Anthracite embossed
painted

AC09
Verniciato gofrato
nero
Black embossed
painted

RIPIANO/Table top

RIPIANO IN VETRO

Glass table top



VE01
Satinato bianco
Satin-finish white

VE02
Satinato antracite
Satin-finish anthracite

VE09
Satinato nero
Satin-finish black

PIANO IN NEWPANN

Newpann top



NEW01
Rovere grigio
Grey oak

NEW02
Rovere sbiancato
Whitened oak

NEW03
Rovere verniciato
nero
Black embossed
painted oak

NEW04
Verniciato gofrato
bianco
Verniciato gofrato
bianco

NEW05
Verniciato antracite
Verniciato antracite

NEW06
Verniciato nero
gofrato
Verniciato nero
gofrato

PROLUNGA/Extension

TELAIO IN ALLUMINIO

Steel frame



NEW04
Verniciato gofrato
bianco
Verniciato gofrato
bianco

NEW05
Verniciato Antracite
Verniciato Antracite

NEW06
Verniciato nero
gofrato
Verniciato nero
gofrato





TRENDSETTER

DESIGN:
PIERVITTORIO PREVEDELLO
LUCA DE CARLI

Extending table with a die-cast aluminium mechanism with strong and decisive design. The legs are in lacquered solid wood, with MDF top. Available in white and sand to match the legs.



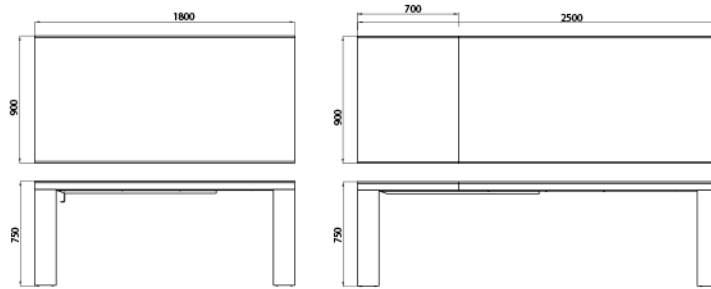

Top
900x1800mm + 700 mm
1000x1200mm + 700 mm

TELAIO/Frame

MASSELLO DI FAGGIO LACCATO GOFFRATO

Lacquered embossed solid beech frame



MAFLG6
Laccato bianco
White lacquered



MAF514
Laccato sabbia
Sand lacquered

RIPIANO/Table top

MDF LACCATO GOFFRATO

Lacquered embossed MDF



MDF03
Bianco
White



MDF04
Sabbia
Sand

PROLUNGA/Extension

MDF LACCATO GOFFRATO

Lacquered embossed MDF



MDF03
Bianco
White



MDF04
Sabbia
Sand



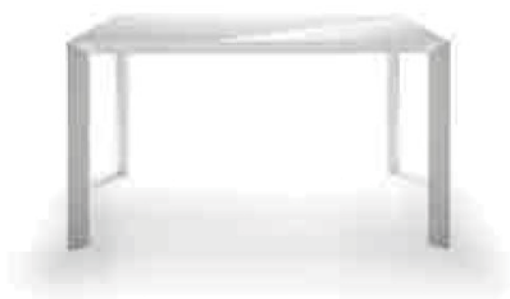

POINTBREAK

DESIGN:
PIERVITTORIO PREVEDELLO
LUCA DE CARLI

Extending table with an aluminium frame, satin-finished glass top and MDF extension.





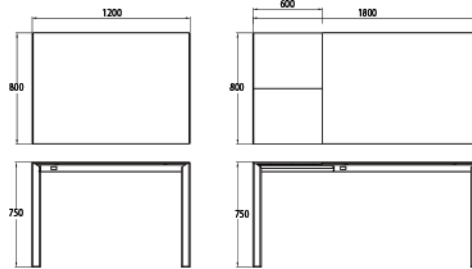

Top

800x1200mm + 600mm

900x1500mm + 600mm

TELAIO/Frame

TELAIO IN ALLUMINIO

Steel frame



AL01
*Verniciato gofrato
bianco*
*White embossed
painted*

AC02
Verniciato opaco sabbia
Matt sand painted

RIPIANO/Table top

RIPIANO IN VETRO

Glass table top



VE01
Satinato bianco
Satin-finish white

VE09
Satinato sabbia
Satin-finish sand

PROLUNGA/Extension

TELAIO IN ALLUMINIO

Steel frame



MDF03
Bianco
White

MDF04
Sabbia
Sand





ELEPHAS

DESIGN:
GIANCARLO BISAGLIA

Fixed table with glass top and polished or painted aluminium legs. The design of the legs is particularly distinctive as they widen at the base.

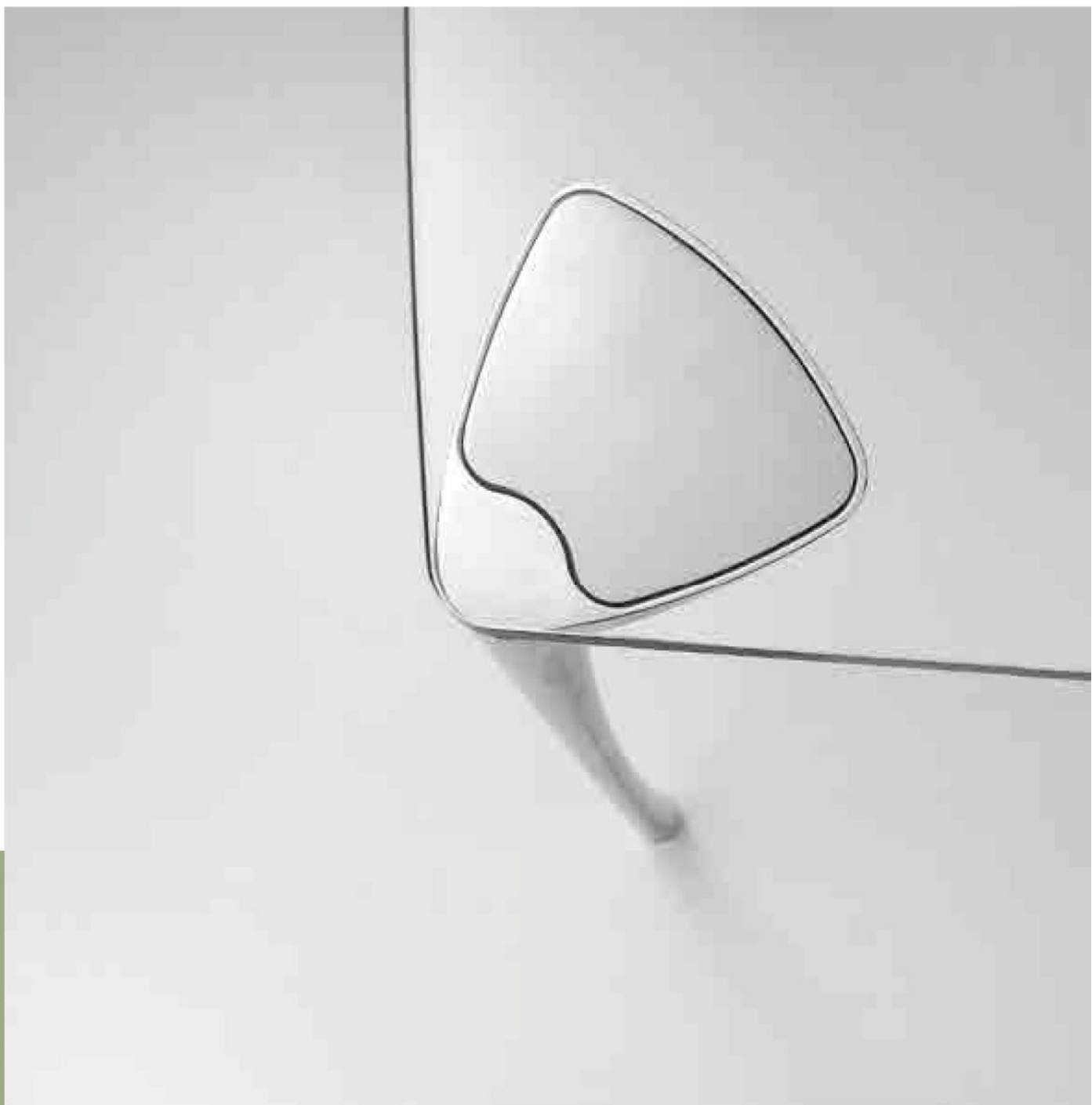

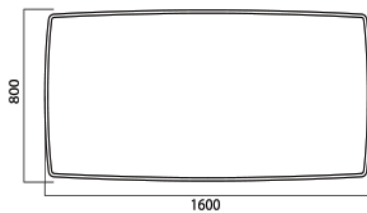

Top
800x1600mm

TELAIO/Frame

TELAIO IN ALLUMINIO

Steel frame



AL04
*Verniciato bianco
lucido
Polished white
painted*

AL05
*Verniciato nero
lucido
Polished black
painted*

AC07
*Pulito
Polished*

RIPIANO/Table top

RIPIANO IN VETRO

Glass table top



VE04
*Satinato bianco
Satin-finish white*

VE05
*Nero
Black*

VE08
*Cristallo trasparente
Clear glass*





EMMA TABLE

DESIGN:
PAOLO FAVARETTO

Arigato is a furnishing accessory with minimal, functional lines. The single 65 cm square element is the ideal base for furnishing any style of wall.

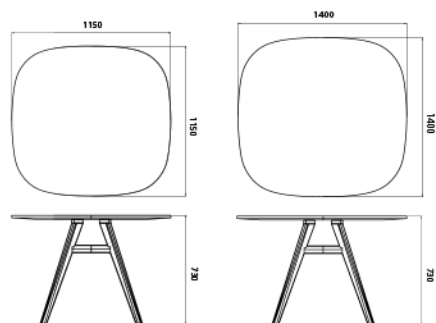

**Top**

1150x1150mm
1200x1200mm

TELAIO/Frame**TELAIO IN MASSELLO DI ROVERE**

Solid oak



MAR01
Rovere sbiancato
Whitened oak



MAR02
Rovere wengè
Wenge-stain oak



MAR03
Rovere naturale
Natural oak

TELAIO IN MASSELLO DI FAGGIO

Solid beech



MAFG3
Faggio naturale
Natural beech



MAFG6
Faggio wengè
Wenge-stain beech



MAFLG6
Faggio laccato
bianco
White lacquered
beech

RIPIANO/Table top**RIPIANO IN PRECOMPOSTO MDF**

MDF plywood shelf



MDF03
Bianco
White



MDF05
Antracite
Anthracite

MDF IMPIALLACCIATO

Veneer



MAR01
Rovere sbiancato
Whitened oak



MAR02
Rovere wengè
Wenge-stain oak



MAR03
Rovere naturale
Natural oak



MDF09
Faggio naturale
Natural beech



MDF10
Faggio wengè
Wenge-stain beech





PORTA VENEZIA TABLE

DESIGN:
DORIGO DESIGN

The concept of the Porta Venezia chair extends to include a table that is ideal for decorating your home. Two types of solid beech wood legs are paired with an MDF top.

— THE PORTA VENEZIA TABLE IS AVAILABLE IN TWO EXTENDING VERSIONS: A SLEEK AND STREAMLINED “SLIM” VERSION AND A CHUNKIER “LIVING” VERSION.



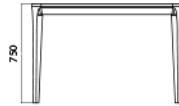
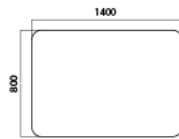

Top
800x1400mm
900x1600mm

PORTA VENEZIA TABLE - LIVING

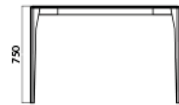
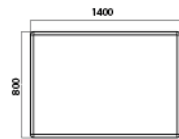

Top
800x1400mm
900x1600mm

TELAIO/Frame

TELAIO IN MASSELLO DI FAGGIO

Solid beech frame



MAFG4
Faggio naturale
Natural beech



MAFC3
Faggio wengè
Wenge-stain beech



MAFLG6
Faggio laccato bianco
White lacquered beech

RIPIANO/Table top

RIPIANO IN PRECOMPOSTO MDF

MDF plywood shelf



MDF03
Bianco
White



MDF05
Antracite
Anthracite

PORTA VENEZIA EXTENDABLE TABLE - SLIM

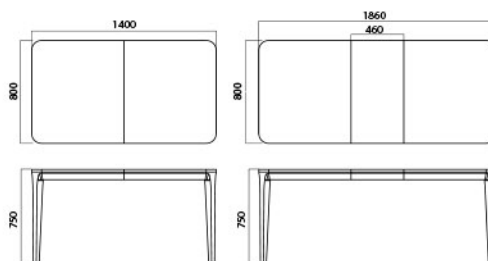

Top

800x1400mm + 460mm

800x1600mm + 460mm

900x1800mm + 560mm

TELAIO/Frame

TELAIO IN MASSELLO DI FAGGIO

Solid beech frame



MAFG4
Faggio naturale
Natural beech



MAFC3
Faggio wengè
Wenge-stain beech



MAFLG6
Faggio laccato
bianco
White lacquered
beech

TELAIO/Frame

RIPIANO IN PRECOMPOSTO MDF

MDF plywood shelf



MDF03
Bianco
White



MDF05
Antracite
Anthracite

RIPIANO/Table top

RIPIANO IN PRECOMPOSTO MDF

MDF plywood shelf



MDF03
Bianco
White



MDF05
Antracite
Anthracite

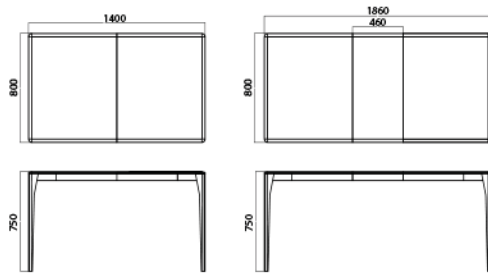

Top

800x1400mm + 460mm

800x1600mm + 460mm

900x1800mm + 560mm

TELAIO/Frame

TELAIO IN MASSELLO DI FAGGIO

Solid beech frame



MAFG4
Faggio naturale
Natural beech



MAFC3
Faggio wengè
Wenge-stain beech



MAFLG6
Faggio laccato bianco
White lacquered beech

TELAIO/Frame

RIPIANO IN PRECOMPOSTO MDF

MDF plywood shelf



MDF03
Bianco
White



MDF05
Antracite
Anthracite

RIPIANO/Table top

RIPIANO IN PRECOMPOSTO MDF

MDF plywood shelf



MDF03
Bianco
White



MDF05
Antracite
Anthracite

PORTA VENEZIA BAR TABLE - SQUARE

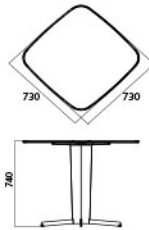

Height
710mm
1070mm

Top
600x600mm
700x700mm
730x730mm
800x800mm

PORTA VENEZIA BAR TABLE - ROUND

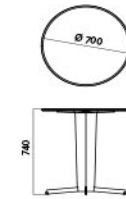

Height
710mm
1070mm

Top
Ø 600mm
Ø 700mm
Ø 800mm

PORTA VENEZIA BAR TABLE - 4 LEGS



*Disponibile solo con piano in MDF.
Available only with MDF top.*

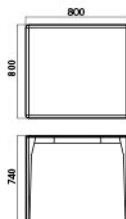

Height
720mm

1400x1400mm

TELAIO/Frame

TELAIO IN MASSELLO DI FAGGIO

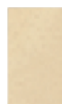

Solid beech frame

MAFG4*Faggio naturale
Natural beech***MAFC3***Faggio wengè
Wenge-stain beech***MAFLG6***Faggio laccato
bianco
White lacquered
beech***RIPIANO/Table top**

RIPIANO IN POLIPROPILENE

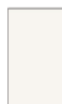

Polypropylene table top

PP20*Bianco
White***PP07***Grigio cemento
Cement grey***PP514***Sabbia
Sand*

RIPIANO IN PRECOMPOSTO MDF



MDF plywood shelf

MDF03*Bianco
White***MDF05***Antracite
Anthracite***BASE/Base**

BASE IN ACCIAIO VERNICIATO



Painted steel base

AC101*Bianco
White***AC102***Nero
Black*





LOOP TABLE

DESIGN:
CLAUS BREINHOLT

The Loop family sees the addition of a table version, ideal for contract settings. Loop table is made up of an aluminium base that supports a square or round top in polypropylene, MDF, Fenix or laminate; available in three different heights.

LOOP ROUND

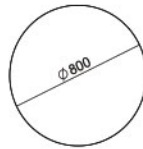
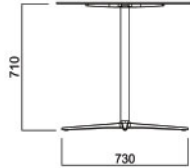

Height	Top
450mm	Ø 800mm
710mm	Ø 600/700/800mm
1070mm	Ø 600/700/800mm

LOOP SQUARE

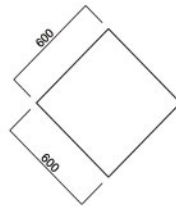
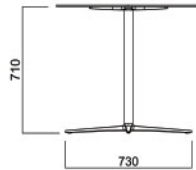

Height	Top
450mm	800x800mm
710mm	600x600/700x700/800x800mm
1070mm	600x600/700x700/800x800mm

TELAIO/Frame**TUBO IN ACCIAIO**

Steel tube

AC20
*Verniciato gofrato
 bianco
 Embossed white
 painted*

AC03
*Verniciato gofrato
 nero
 Embossed black
 painted*

AC01
*Cromato
 Chromium-plated*

PIANO/Table top**POLIPROPILENE**

Polypropylene

PP20
*Bianco
 White*

PP07
*Grigio cemento
 Cement grey*

PP514
*Sabbia
 Sand*

RIPIANO IN PRECOMPOSTO MDF

MDF plywood shelf



MDF03
*Bianco
 White*

LAMINATO

Laminate

LMFO1
*Bianco
 White*

LM02
*Nero
 Black*

LM08
*Grigio cemento
 Cement grey*

LM07
*Sabbia
 Sand*

FENIX

Fenix



FX01
*Bianco
 White*

FX02
*Nero
 Black*





LINE

DESIGN:
BROGLIATO TRAVERSO

Practical bar table with squared rod structure and 4 star base, black or white painted. The top can be round or square and is available in different finishes.

LINE - CIRCLE



Height:
720mm

Top:
Ø 700mm

LINE - SQUARE

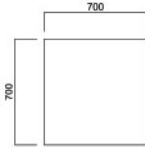

Height:
720mm

Top:
700x700mm

TELAIO/Frame

TELAIO IN ACCIAIO



Steel frame

AC30*Bianco opaco**White matt painted***AC31***Nero opaco**Black matt painted***PIANO/Table top**

POLIPROPILENE



Polypropylene

PP20*Bianco**White***PP07***Grigio cemento**Cement grey***PP514***Sabbia**Sand*

LAMINATO



Laminate

LMF01*Bianco**White***LM02***Nero**Black***LM08***Grigio cemento**Cement grey***LM07***Sabbia**Sand*

RIPIANO IN PRECOMPOSTO MDF



MDF plywood shelf

MDF03*Bianco**White*

FENIX



Fenix

FX01*Bianco**White***FX02***Nero**Black*





BOMBÈ

DESIGN:
INFINITI DESIGNERS

Table designed for commercial areas. Single central leg in chromium-plated square-section steel tubing, with a stainless steel flat base and top fixing aluminium plate. Available in 3 different heights and with various types of tabletop (polypropylene, laminate, Fenix and MDF).

BOMBÈ ROUND

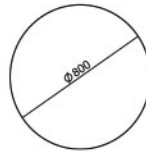
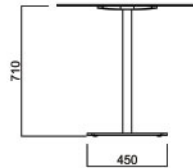

Height	Top
450mm	Ø 800mm
710mm	Ø 600/700/800mm
1070mm	Ø 600/700/800mm

BOMBÈ SQUARE

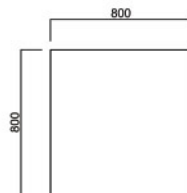
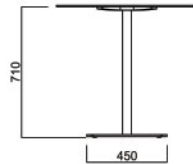

Height	Top
450mm	800x800mm
710mm	600x600mm/700x700mm/800x800mm
1070mm	600x600mm/700x700mm/800x800mm

TELAIO/Frame**TUBO IN ACCIAIO**

Steel tube

AC20
*Verniciato goffrato
 bianco
 Embossed white
 painted*

AC03
*Verniciato goffrato
 nero
 Embossed black
 painted*

AC01
*Cromato
 Chromium-plated*

PIANO/Table top**POLIPROPILENE**

Polypropylene

PP20
*Bianco
 White*

PP07
*Grigio cemento
 Cement grey*

PP514
*Sabbia
 Sand*

RIPIANO IN PRECOMPOSTO MDF

MDF plywood shelf



MDF03
*Bianco
 White*

LAMINATO

Laminate



LMF01
*Bianco
 White*

LM02
*Nero
 Black*

LM08
*Grigio cemento
 Cement grey*

LM07
*Sabbia
 Sand*

FENIX

Fenix



FX01
*Bianco
 White*

FX02
*Nero
 Black*





DROP TABLE

DESIGN:
ORLANDINI&RADICE

Lightweight, practical and highly stackable, the Drop table has been designed for outdoor use.



— MANUFACTURED IN GLASS-FIBRE REINFORCED POLYPROPYLENE WITH CO-INJECTION MOULDING WITH A SECOND MATERIAL, THE DROP TABLE IS AVAILABLE IN THE SQUARE OR ROUND VERSION.

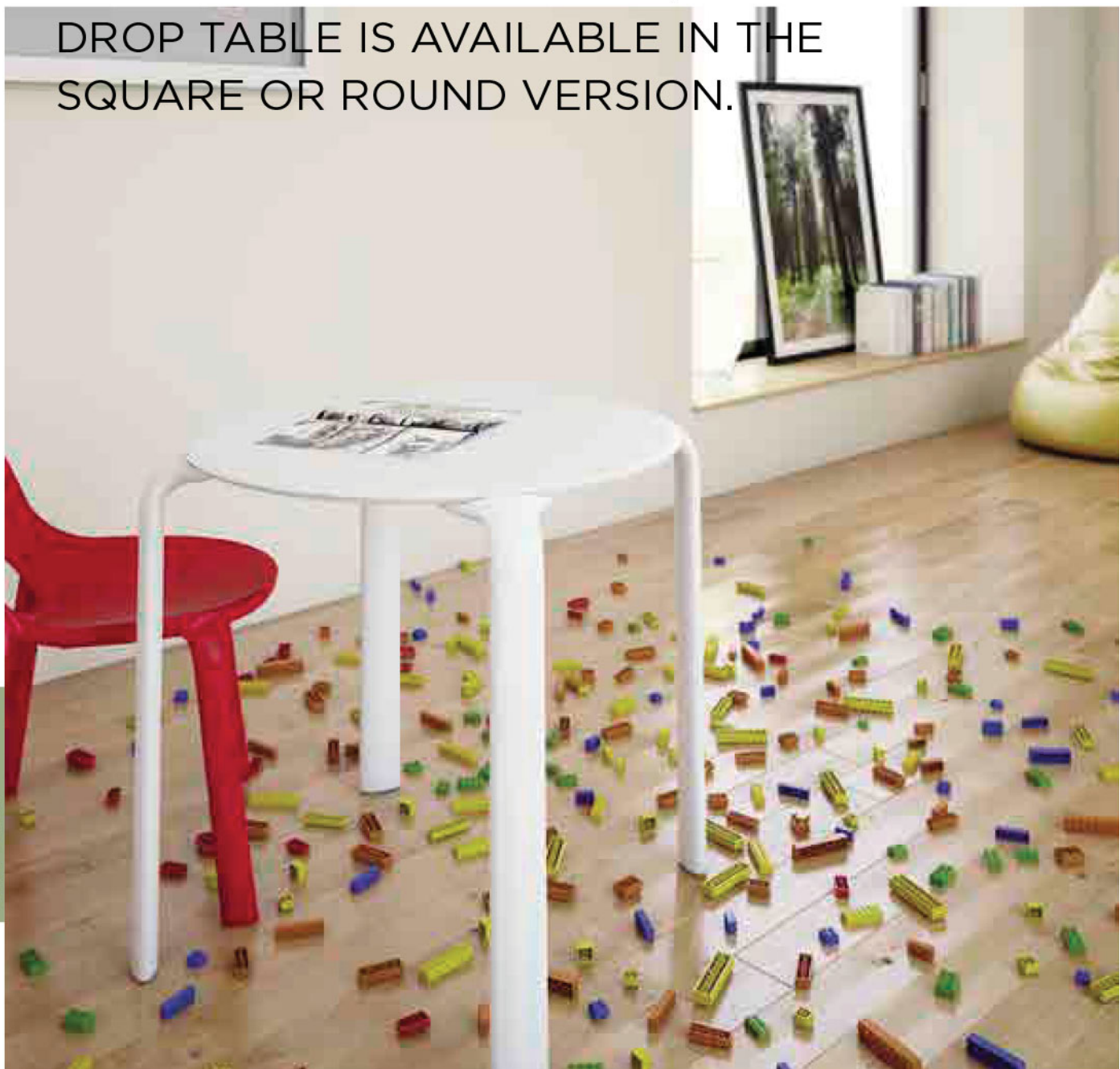

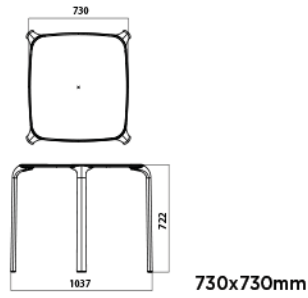
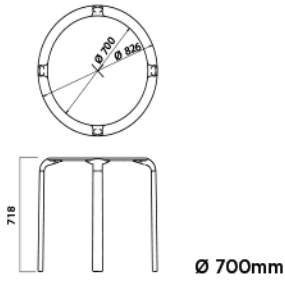

POLIPROPILENE

Polypropylene



PP20
Bianco
White



PP07
Grigio cemento
Cement grey



PP514
Sabbia
Sand





3-POD

DESIGN:
GIANCARLO BISAGLIA

The ideal solution for public areas: the base of the 3-Pod table is a central aluminium leg and the top is available in Alucompact and polypropylene, making the table suitable for outdoor use.

3-POD PIANO FISSO

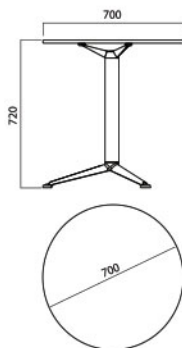

Height	Top
710mm	Ø 600/700/800mm
1070mm	Ø 600/700/800mm



3-POD PIANO RIBALTABILE

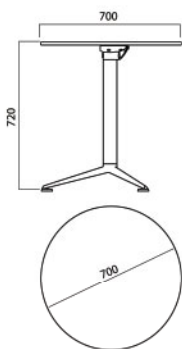

Height	Top
710mm	Ø 600/700/800mm
1070mm	Ø 600/700/800mm



OPTIONAL PER ESTERNO DISPONIBILE SOLO
NELLA VERSIONE CON STRUTTURA ALLUMINIO VERNICIATO
E PIANO IN POLIPROPILENE.

Optional for outdoor available only for version with aluminium varnished
structure and polypropylene top.

TELAIO/Frame**TUBO IN ALLUMINIO**

Aluminium tube

AL01
*Verniciato bianco
 goffrato
 Embossed white
 painted*

AL09
*Verniciato nero
 goffrato
 Embossed black
 painted*

AL07
*Lucido
 Polished*

PIANO/Table top**POLIPROPILENE**

Polypropylene



PP20
*Bianco
 White*

PP07
*Grigio cemento
 Cement grey*

PP514
*Sabbia
 Sand*

RIPIANO IN PRECOMPOSTO MDF

MDF plywood shelf



MDF03
*Bianco
 White*

LAMINATO

Laminate



LMF01
*Bianco
 White*

LM02
*Nero
 Black*

LM08
*Grigio cemento
 Cement grey*

LM07
*Sabbia
 Sand*

FENIX

Fenix



FX01
*Bianco
 White*

FX02
*Nero
 Black*





PLANO

DESIGN:
INFINITI DESIGNERS

Bar table available in high or low versions. Single central square leg with flat base. The frame can be chromium-plated or painted, the top is in black or white Alucompact and has a top fixing aluminium plate.

PLANO

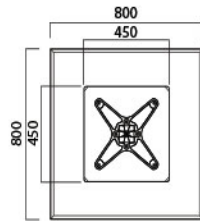

Height	Top
450mm	800x800mm
710mm	600x600mm/700x700mm/730x730/800x800mm
1070mm	600x600mm/700x700mm/730x730/800x800mm

TELAIO/Frame**TUBO IN ACCIAIO**

Steel tube

AC20
*Verniciato goffrato
 bianco
 Embossed white
 painted*

AC03
*Verniciato goffrato
 nero
 Embossed black
 painted*

AC01
*Cromato
 Chromium-plated*

PIANO/Table top**POLIPROPILENE**

Polypropylene

PP20
*Bianco
 White*

PP07
*Grigio cemento
 Cement grey*

PP514
*Sabbia
 Sand*

RIPIANO IN PRECOMPOSTO MDF

MDF plywood shelf



MDF03
*Bianco
 White*

LAMINATO

Laminate



LMF01
*Bianco
 White*

LMO2
*Nero
 Black*

LMO8
*Grigio cemento
 Cement grey*

LM07
*Sabbia
 Sand*

FENIX

Fenix



FX01
*Bianco
 White*

FX02
*Nero
 Black*

FINISHES

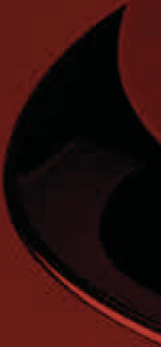

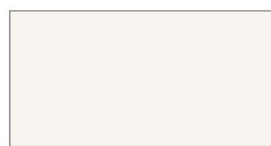
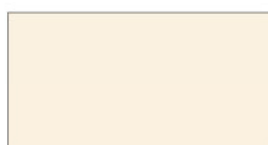

POLIPROPILENE - Polypropylene

**PP20** Bianco - White**PP21** Grigio perla - Pearl grey**PP7001** Grigio titanio - Titanium grey**PP07** Grigio cemento - Cement grey**PP11** Antracite - Anthracite**PP102C** Giallo mimosa - Mimosa yellow**PP1016** Giallo limone - Lemon yellow**PP1023** Giallo mais - Corn yellow**PP1012** Senape - Mustard**PP514** Sabbia - Sand**PP02** Arancione - Orange**PP166U** Mattone - Brick red**PP3020** Rosso - Red**PP3005** Vinaccia - Burgundy**PP22** Tabacco - Tobacco**PP512** Verde avocado - Avocado green**PP6018** Verde tropicale - Tropical green**PP513** Verde militare - Military green**PP4001** Viola - Purple**PP2905C** Celeste - Light blue**PP5019** Blu Capri - Capri blue**PP516** Blu navy - Navy blue**PP9001** Bianco crema - Off-white**PP9010** Bianco puro - Pure white**PP31** Nero carbone - Coal black**PP32** Grigio ardesia - Slate grey**PP421C** Grigio mandorla - Almond**PP480C** Cipria - Cipria**PP557C** Verde acqua - Light teal**PP7608C** Marsala - Marsala**PP23** Grigio medio - Medium grey**PP24** Grigio luce - Light grey**PP25** Biscotto - Biscuit**PP26** Beige - Beige



PP27 Curry - Curry



PP28 Avorio - Ivory



PP29 Verde oliva - Olive green



PP30 Verde kaki - Khaki green



PP33 Arancio carota - Carrot orange



PP34 Pesca - Peach



***PP01** Nero - Black

* Il polipropilene presenta delle "ombreggiature" che risultano più evidenti nel colore nero rispetto agli altri. Sono comunque da ritenersi nella norma, perchè sono una caratteristica intrinseca del materiale. Polypropylene has "shadings" which are more evident in black than in the other colours. This is an intrinsic characteristic of polypropylene and therefore a normal feature of the material.

POLIAMMIDE – Polyamide

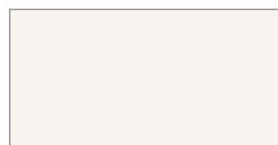

PA101 Bianco - White



PA117 Grigio siliceo - Silica grey



PA102 Nero - Black



PA114 Rosso - Red



PA120 Giallo - Yellow



PA119 Verde - Green



PA121 Blu Capri - Capri blue

POLIETILENE – Polyethylene



PE301 Giallo - Yellow



PE303 Verde - Green



PE302 Grigio - Grey

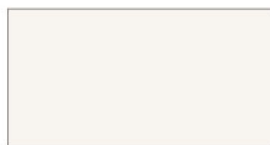

PE300 Bianco - White



PE304 Neutro - Neutral

POLIURETANO – Polyurethane

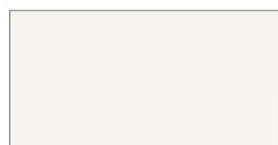

PU02 Bianco - White



PU12 Avorio - Ivory



PU04 Argento - Silver



PU11 Antracite - Anthracite



PU03 Nero - Black



PU16 Pistacchio - Pistachio



PU05 Viola - Purple



PU01 Rosso - Red



PU10 Caffè - Coffee



PU15 Grigio traffico - traffic grey



PU14 Rosso rubino - Ruby red



PU13 Sabbia - Sand



PU06 Verde mela - Green apple



PU17 Giallo - Yellow

POLICARBONATO TRASPARENTE - Transparent polycarbonate



PC103 Ghiaccio - Ice



PC104 Fumé - Smoke-grey



PC109 Ciclamino - Cyclamen



PC111 Ambra - Amber



PC123 Vinaccia - Burgundy

POLICARBONATO COPRENTE - Solid colour polycarbonate

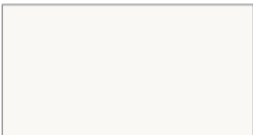

PC101 Bianco - White



PC102 Nero - Black



PC114 Rosso - Red



PC117 Grigio siliceo



PC118 Arancione - Orange



PC126 Antracite - Anthracite



PC124 Giallo dalia - Dalia yellow



PC125 Sabbia - Sand



PC128 Tabacco - Tobacco



PC130 Verde foglia - Green leaf

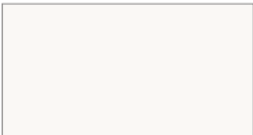

PC131 Bianco - White - Blanco

ABS
ABS COPRENTI - Solid colour ABS

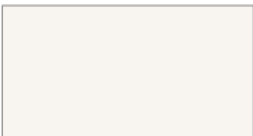

ABS101 Bianco - White



ABS102 Nero - Black



ABS114 Rosso - Red

LEGNO MULTISTRATO – Plywoodo



LV01 Classic Sapell Mocca



LV07 Classic Brown Olive Ash



LV03 Classic Black Cherry Elegant



LV04 Classic Amazakoue Elegant



LV05 Nimbus Sapell Sycamore



LV06 Stratus Superlor American Walnut



LR01
Rovere sbiancato
Whitened oak



LR02
Rovere wengè
Wenge-stain oak



LR03
Rovere naturale
Natural oak



LR04
Rovere verniciato ocra
Ochre painted oak



LR05
Rovere verniciato bordeaux
Bordeaux painted oak



LR06
Rovere verniciato antracite
Anthracite painted oak



LR07
Rovere verniciato verde
Green painted oak



LR08
Rovere verniciato nero
Black painted oak



LFR01
Faggio naturale
Natural beech



LFR02
Faggio wengè
Wenge-stain beech



LFR01
Frassino naturale
Natural ash



LFR02
Frassino wengè
Wenge ash



LFR03
Frassino sbiancato
Whitened ash



LFR04
Frassino verniciato ocra
Ochre stained ash



LFR05
Frassino verniciato bordeaux
Bordeaux stained ash



LFR06
Frassino verniciato verde
Green stained ash



LFR07
Frassino verniciato grigio
Grey stained ash



LFR08
Frassino verniciato nero
Black stained ash

MASSELLO DI FAGGIO – Solid beech



MAFGV
Faggio naturale
Natural beech



MAFC3
Faggio wengè
Wenge-stain beech



MAF514
Faggio laccato sabbia
Sand lacquered beech

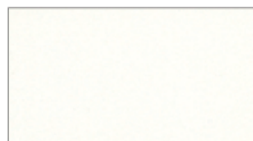

MAFLG6
Faggio laccato bianco
White lacquered beech



MAF01
Faggio laccato grigio siliceo
Silica grey lacquered beech



MAF02
Faggio laccato nero
Black lacquered beech



MAF03
Faggio laccato rosso
Red lacquered beech



MAF04
Faggio laccato giallo
Yellow lacquered beech



MAF05
Faggio laccato verde
Green lacquered beech



MAF06
Faggio laccato blu Capri
Capri blue lacquered beech



MAF104
Faggio verniciato nero
Black painted beech

MASSELLO DI ROVERE – Solid oak



MAR01
Rovere sbiancato
Whitened oak



MAR02
Rovere wengè
Wenge-stain oak



MAR03
Rovere naturale
Natural oak



MAR04
Rovere verniciato ocra
Ochre painted oak



MAR05
Rovere verniciato bordeaux
Bordeaux painted oak



MAR06
Rovere verniciato antracite
Anthracite painted oak



MAR07
Rovere verniciato verde
Green painted oak



MAR08
Rovere verniciato nero
Black painted oak

MASSELLO DI IROKO – Solid Iroko wood



IRK01
Tinto nero
Black painted

LAMINATO - Laminate

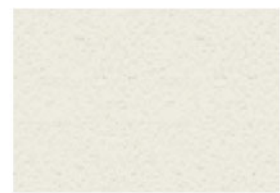

LM01
Bianco
White

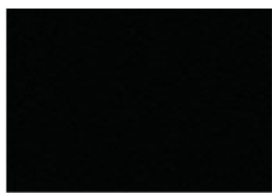

LM02
Nero
Black



LM04
Grigio nube
Cloud grey



LM07
Sabbia
Sand



LM08
Grigio cemento
Cement grey

*FENIX

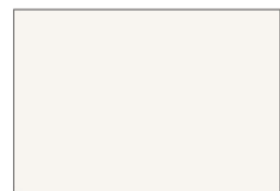

FX01
Bianco
White



FX02
Nero
Black

* È un materiale innovativo con core ottenuto da composto di carta impregnata in resina termoindurente mentre la superficie decorativa, ottenuta con l'ausilio di nanotecnologie, è costituita da una carta decorativa trattata con resine di nuova generazione. È un materiale che si distingue per particolari caratteristiche quali: alta resistenza al graffio e al calore, anti impronta, morbidezza al tatto, bassa riflessione della luce, riparabilità termica dei micrograffi, alta attività di abbattimento della carica batterica.

* It is an innovative material with a core obtained from a compound of paper impregnated with thermo-hardening resin. The decorative surface, obtained with the aid of nanotechnologies, comprises a decorative paper treated with new generation resins. This material stands out for its special features as follows: high resistance to scratches and heat, fingerprint resistant, soft to the touch, low light reflection, thermal healing of micro-scratches and enhanced anti-bacterial properties.

PRECOMPOSTO MDF – Multilaminar wood MDF

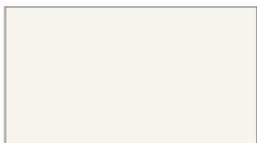

MDF03
Laccato bianco gofrato
Embossed white lacquered



MDF04
Laccato sabbia gofrato
Embossed sand lacquered



MDF05
Laccato antracite gofrato
Embossed anthracite
lacquered



MDF06
Impiallacciato rovere
sbiancato
Whitened oak veneer



MDF07
Impiallacciato rovere wengè
Wenge-stain oak veneer



MDF08
Impiallacciato rovere
naturale
Natural oak veneer



MDF09
Impiallacciato faggio
naturale
Natural beech veneer



MDF10
Impiallacciato faggio wengè
Wenge-stain beech veneer

PELLE FIORE – Full-grain leather

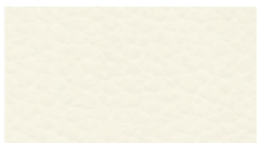

PW Bianco - White



PB Avorio - Ivory



PT Tortora - Dove grey



PR Rosso - Red



PTM Testa di moro -
Dark brown



PN Nero - Black

ECOPELLE – Eco leather – Simil piel

Composizione 76%PVC - 2%PU - 22%PES
 Altezza 140 cm
 Peso: g/m2 540 +/-10
 Martindale cicli (ISO 5470-2): 60000
 Solidità colori allo sfregamento a secco (ISO 105-X12): 4/5
 Solidità colori allo sfregamento a umido ISO 105-X12: 4/5
 Solidità colori alla luce (Xenotest - blu scale) (ISO 105-B02): 6
 Adesione (ISO 2411): > 40
 Resistenza alla trazione (UNI EN ISO 1421): 600 long.
 Resistenza alla trazione (UNI EN ISO 1421): 310 trasv.
 Allungamento a rottura % (UNI EN ISO 1421): 57 long.
 Allungamento a rottura % (UNI EN ISO 1421): 120 trasv.
 Resistenza alla lacerazione (UNI EN ISO 4674): 50 long.
 Resistenza alla lacerazione (UNI EN ISO 4674): 50 trasv.
 Resistenza alle flessioni cicli (UNI 4818-13): 100000
 Test ignifugo: EN 1021-2:2006 / UNI 9175 classe 1 IM /
 BS5852-1:1979 part I - TB 117:2013

Composition: 76%PVC - 2%PU - 22%PES
 Width: 140 cm
 Weight: g/m2 540 +/-10
 Cycles (ISO 5470-2): 60000
 Colour fastness to dry rubbing (ISO 105-X12): 4/5
 Colour fastness to wet rubbing (ISO 105-X12): 4/5
 Colour fastness to light (Xenotest - blu scale) (ISO 105-B02): 6
 Adhesion (ISO 2411): > 40
 Tensile strenght (UNI EN ISO 1421): 600 long.
 Tensile strenght (UNI EN ISO 1421): 310 trasv.
 Elongation at break % (UNI EN ISO 1421): 57 long.
 Elongation at break % (UNI EN ISO 1421): 120 trasv.
 Tear strenght (UNI EN ISO 4674): 50 long.
 Tear strenght (UNI EN ISO 4674): 50 trasv.
 Cycles (UNI 4818-13): 100000
 Fireproof test: EN 1021-2:2006 / UNI 9175 classe 1 IM /
 BS5852-1:1979 part I - TB 117:2013



FELTRO – Felt – Fiettro

100% Lana - 100% Wool

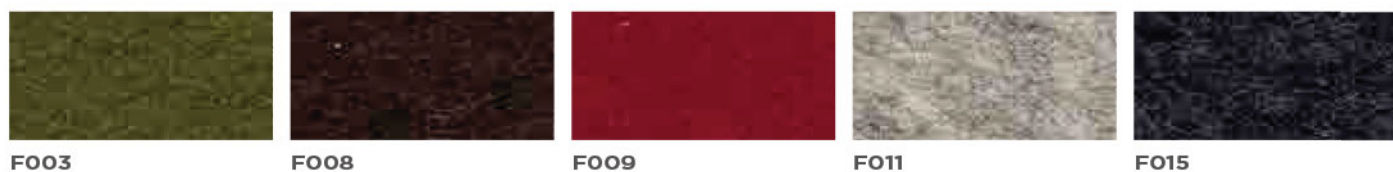

FIELD KVADRAT

Designer: Alfredo Häberli
 Composizione: 100% Trevira CS
 Altezza: 140 cm
 Cimossa:
 Peso: 430 g/mtl
 Resistenza alla luce: 6-7 (ISO 1-8)
 Abrasione: 100.000 Martindale
 Colore: possono riscontrarsi lievi differenze
 L'ambiente: limitato impatto ambientale

Designer: Alfredo Häberli
 Composition: 100% Trevira CS
 Height: 140 cm
 Selvedge:
 Weight: 430 g/mtl
 Light resistance: 6-7 (ISO 1-8)
 Abrasion: 100.000 Martindale
 Colour: there may be slight differences
 The environment: reduced environmental impact

Test ignifugo - Fireproof test
 BS 5852 Crib 5
 BS 5852 part 1, ig. s. 0
 DIN 4102 B1
 EN 1021-1/2
 FAR 25.853
 IMO FTP Code 2010 Part 8
 NF D 60 013
 NF P 92 507 M1
 ÖNORM B1/Q1
 SN 198 898 5.2
 UNI 9175 IIM
 UNI 9177 Classe 1
 US Cal. Bull. 117-2013

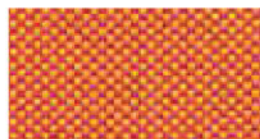

FD542

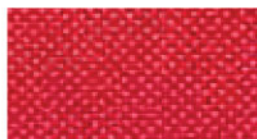

FD642



FD662



FD382



FD252



FD242

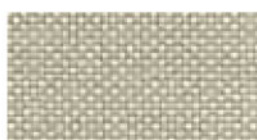

FD232



FD432



FD222



FD932



FD982



FD972



FD942

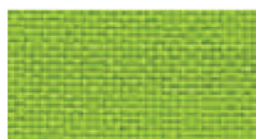

FD952



FD172



FD182



FD132



FD142



FD192



FD782



FD752



FD762

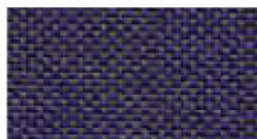

FD772



FD682

UMAMI KVADRAT

Designer: Louise Sigvardt
 Composizione: 90% Lana vergine, 10% nylon
 Altezza: 140 cm
 Cimossa:
 Peso: Umami 420 g/lin.m -
 Umami 2 510 g/lin.m - Umami 3 470 g/lin.m
 Resistenza alla luce: 6-7 (ISO 1-8)
 Abrasione: Umami 80.000 Martindale
 Umami 2 100.000 Martindale
 Umami 3 60.000 Martindale
 Colore: possono riscontrarsi lievi differenze
 L'ambiente: fibre naturali/risorsa rinnovabile

Designer: Louise Sigvardt
 Composition: 90% new wool worsted, 10% nylon
 Height: 140 cm
 Selvedge:
 Weight: Umami 420 g/lin.m -
 Umami 2 510 g/lin.m - Umami 3 470 g/lin.m
 Light resistance: 6-7 (ISO 1-8)
 Abrasion: Umami 80.000 Martindale
 Umami 2 100.000 Martindale
 Umami 3 60.000 Martindale
 Colour: there may be slight differences
 The enviroment: natural fibres / renewable resource

Test ignifugo - Fireproof test
 AS/NZS 3837, class 2
 BS 5852 Crib 5 with treatment
 BS 5852 part 1
 EN 1021-1/2
 IMO FTP Code 2010 Part 8
 NF D 60 013
 UNI 9175 11M
 US Cal. Bull. 117-2013

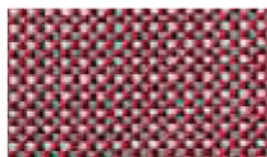

UM532

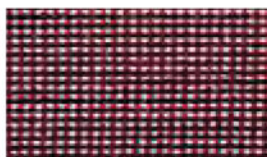

UM551



UM572



UM512

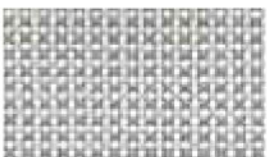

UM122

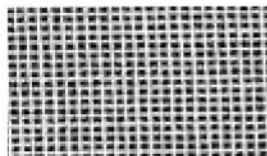

UM111

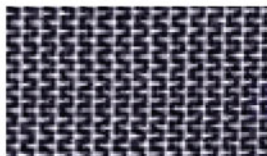

UM743

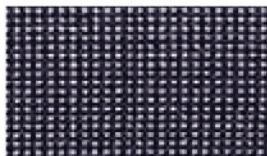

UM191



UM172

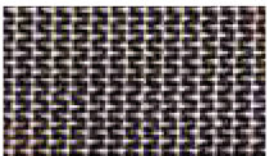

UM773

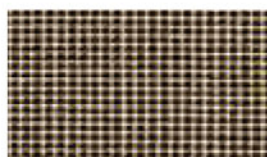

UM251

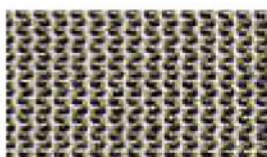

UM223

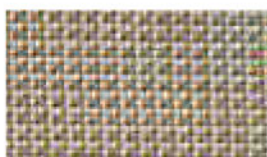

UM212



UM332

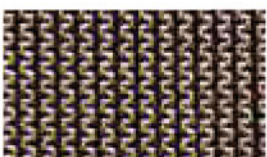

UM353

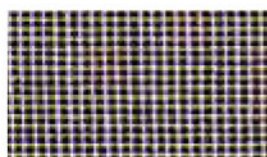

UM621

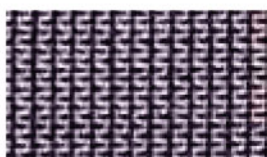

UM653



UM982

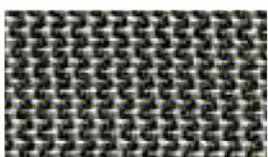

UM973

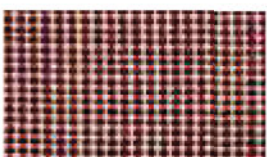

UM441

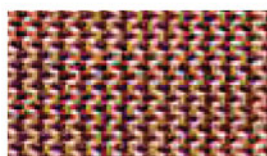

UM453

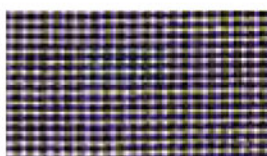

UM721

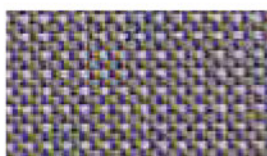

UM712



UM762

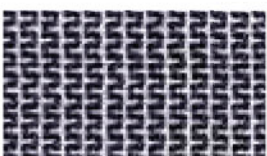

UM143

CANVAS KVADRAT

Designer: Giulio Ridolfo
 Composizione: 90% Lana Vergine pettinata, 10% nylon
 Altezza: 140 cm
 Cimosa: ↓
 Peso: 480 g/mtl
 Resistenza alla luce: 6-7 (ISO 1-8)
 Abrasion: 100000 Martindale
 Colore: possono riscontrarsi lievi differenze
 L'ambiente: In accordo con le normative ambientali EU

Height: 140 cm
 Selvege: ↓
 Weight: 480 g/mtl
 Light resistance: 6-7 (ISO 1-8)
 Abrasion: 100000 Martindale
 Colour: there may be slight differences
 The environment: In compliance with EU environmental regulations

Test ignifugo - Fireproof test - Test Prueba ignifugo:
 AS/NZS 1530.3
 BS 5852 ig. s. 2-3
 DIN 4102 B2
 EN 1021-1/2
 IMO A.652(16)
 NF D 60 013
 NFPA 260
 UNI 9175 11M
 US Cal. Tech. Bull. 117
 ÖNORM B1/Q1

Designer: Giulio Ridolfo
 Composition: 90% New wool worsted, 10% Nylon



CV244

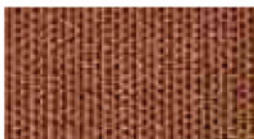

CV454

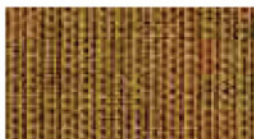

CV424



CV644

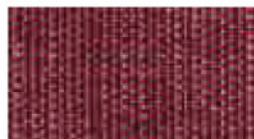

CV654



CV694

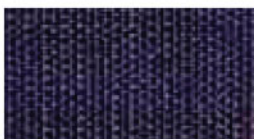

CV684

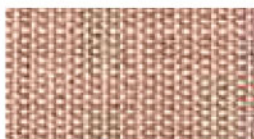

CV614



CV674



CV374

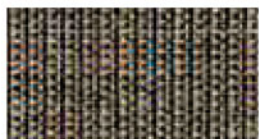

CV264



CV254



CV854

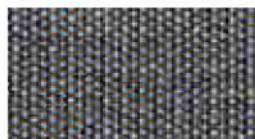

CV734



CV794



CV764



CV224



CV114



CV124



CV134



CV154

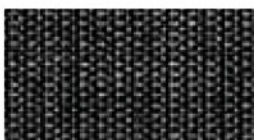

CV174



CV964



CV414



CV984



CV364

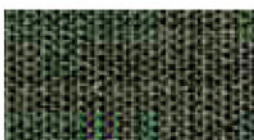

CV974

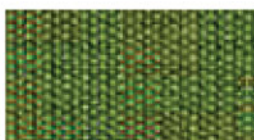

CV954

CAVA 3 KVADRAT

Designer: Anne Gry
 Composizione: 90% Lana Vergine, 10% nylon
 Altezza: 135 cm
 Cimossa: †
 Peso: 460 g/mtl
 Resistenza alla luce: 5-7 (ISO 1-8)
 Abrasione: 80000 Martindale
 Colore: possono riscontrarsi lievi differenze
 Nei colori chiari possono essere presenti fibre di tonalità scure.
 L'ambiente: In accordo con le normative ambientali EU

Designer: Anne Gry
 Composition: 90% New wool worsted, 10% Nylon
 Height: 135 cm
 Selvedge: †
 Weight: 460 g/mtl
 Light resistance: 5-7 (ISO 1-8)
 Abrasion: 80000 Martindale
 Colour: there may be slight differences
 The light colours may contain dark fibres
 The environment: In compliance with EU environmental regulations

Test ignifugo - Fireproof test:
 AS/NZS 1530.3
 AS/NZS 3837 class 2
 BS 5852 ig. s. 2-3
 DIN 4102 B2, ÖNORM B1/G1
 EN 1021-1/2
 IMO A.652(16)
 NF D 60 013
 UNI 9175, IIM
 US Cal. Tech. Bull. 117



CA142



CA192



CA373



CA552



CA953



CA794



CA153



CA652



CA432



CA442

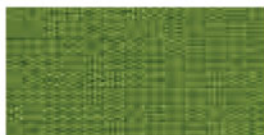

CA883



CA972

DIVINA 3 KVADRAT

Designer: Finn Sködt
 Composizione: 100% Lana
 Altezza: 150 cm
 Cimossa: †
 Peso: 840 g/mtl
 Resistenza alla luce: 5-7 (ISO 105-B02)
 Abrasione: 45000 Martindale
 Colore: possono riscontrarsi lievi differenze
 Nei colori chiari possono essere presenti fibre di tonalità scure.
 L'ambiente: Fibre naturali / risorsa rinnovabile

Designer: Finn Sködt
 Composition: 100% WO
 Height: 150 cm
 Selvedge: †
 Weight: 840 g/mtl
 Light resistance: 5-7 (ISO 105-B02)
 Abrasion: 45000 Martindale
 Colour: there may be slight differences.
 The light colours may contain dark fibres.
 The environment: Natural fibres / renewable resource

Test ignifugo - Fireproof test:
 AS/NZS 1530.3
 BS 5852 ig. s. 5
 BS 5867, part 2, type B
 DIN 4102 B2, ÖNORM B1/G1
 EN 1021-1/2
 EN 13501, C-s1, d0, glued
 IMO A.652(16)
 NF D 60 013
 NFPA 260
 UNI 9175, IIM
 US Cal. Tech. Bull. 117



DV106



DV171



DV173



DV356



DV191



DV236



DV936



DV426



DV542



DV623



DV696



DV684



DV676



DV893



DV886

kvadrat

DIVINA MELANGE 2 KVADRAT

Designer: Finn Sködt
 Composizione: 100% Lana
 Altezza: 150 cm
 Cimossa: ↓
 Peso: 840 g/mtl
 Resistenza alla luce: 5-7 (ISO 105-B02)
 Abrasione: 45000 Martindale
 Colore: possono riscontrarsi lievi differenze
 L'ambiente: Fibre naturali / risorsa rinnovabile

Designer: Finn Sködt
 Composition: 100% WO
 Height: 150 cm
 Selvedge: ↓
 Weight: 840 g/mtl
 Light resistance: 5-7 (ISO 105-B02)
 Abrasion: 45000 Martindale
 Colour: there may be slight differences.
 The environment: Natural fibres / renewable resource

Test ignifugo - Fireproof test:
 AS/NZS 1530.3
 BS 5852 ig. s. 5
 BS 5867, part 2, type B
 DIN 4102 B2, ÖNORM B1/Q1
 EN 1021-1/2
 EN 13501, C-s1, d0, glued
 IMO A.652(16)
 NF D 60 013
 NFPA 260
 UNI 9175, IIM
 US Cal. Tech. Bull. 117



DM220



DM260



DM180



DM571



DM521



DM671



DM721



DM871



DM471



DM421

OUTBACK KVADRAT

Designer: Giulio Ridolfo
 Composizione: 80% Lana Vergine, 20% nylon
 Altezza: 140 cm
 Cimossa: ↓
 Peso: 560 g/mtl
 Resistenza alla luce: 6-7 (ISO 1-8)
 Abrasione: 100000 Martindale
 Colore: possono riscontrarsi lievi differenze
 L'ambiente: Fibre naturali / risorsa rinnovabile

Designer: Giulio Ridolfo
 Composition: 80% WO, 20% nylon
 Height: 140 cm
 Selvedge: ↓
 Weight: 560 g/mtl
 Light resistance: 6-7 (ISO 1-8)
 Abrasion: 100000 Martindale
 Colour: there may be slight differences.
 The environment: Natural fibres / renewable resource

Test ignifugo - Fireproof test:
 : BS 5852 ig. s. 2-3
 DIN 4102 B2,
 EN 1021-1/2
 IMO A.652(16)
 NF D 60 013
 UNI 9175, IIM
 US Cal. Tech. Bull. 117
 ÖNORM B1/Q1



OU221



OU331



OU141



OU961



OU641

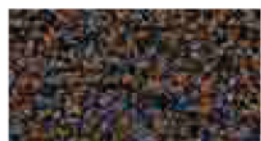

OU451



OU671



OU951



OU781



OU851



OU861

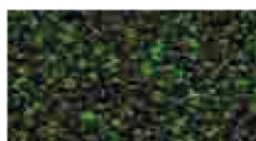

OU941

FLASH NO-SHRINK

Composizione: 100% PP
 Altezza totale: 140 cm (UNI EN 1773)
 Peso al metro lineare: 450 g/LM ($\pm 4\%$)
 Peso al metro quadro: 320 g/m² ($\pm 4\%$) (UNI 5114)
 Resistenza all'abrasione ("Martindale"). N° cicli: 70000 Punto finale (ISO 12947-2)
 Resistenza al pilling: 5 (ISO 12945-2)
 Resistenza alla trazione: Lunghezza 1398,87 - Altezza 1091,41 (ISO 13934-1)
 Allungamento alla rottura: Lunghezza 48,23% - 26,33% Altezza (ISO 13934-1)
 Res. allo scorrimento fili (6 mm): Lunghezza >200 - Altezza >200 (ISO 13936-1)
 Solidità del colore allo sfregamento a secco: scarica CO 4/5 (ISO 105-X12)
 Solidità del colore allo sfregamento ad umido: scarica CO 4/5 (ISO 105-X12)
 Solidità del colore alla luce. Degradato: chiari 5, medi 4, scuri 5 (ISO 105 B02)

Composition: 100% PP
 Total width: 140 cm (UNI EN 1773)
 Weight per linear meter: 450 g/LM ($\pm 4\%$)
 Weight per square meter: 320 g/m² ($\pm 4\%$) (UNI 5114)
 ("Martindale") Abrasion resistance. Rubs: 70000 End point (ISO 12947-2)
 Pilling resistance: 5 (ISO 12945-2)
 Tensile strength: Length 1398,87 - Width 1091,41 (ISO 13934-1)
 Maximum elongation: Length 48,23% - 26,33% Width (ISO 13934-1)
 Seam slippage (6 mm): Length >200 - Width >200 (ISO 13936-1)
 Colour fastness rubbing (dry): staining CO 4/5 (ISO 105-X12)
 Colour fastness rubbing (wet): staining CO 4/5 (ISO 105-X12)
 Colour fastness artificial light. Colour change: light 5, medium 4, dark 5 (ISO 105 B02)

IRRESTRINGIBILE
 NO-SHRINK



BYTE

Composizione 100% PL

Altezza totale: 140 cm (UNI EN 1773)

Peso al metro lineare: 460 g/LM (± 4%)

Resistenza all'abrasione ("Martindale"). N° cicli: 30.000 Punto finale (ISO 12947-2)

Resistenza al pilling: 4/5 (ISO 12945-2)

Resistenza alla trazione: Lunghezza 1000 - Altezza 1300 (ISO 13934-1)

Res. alla stramatura a <6 mm: Lunghezza >200 - Altezza >200 (ISO 13936-1)

Solidità del colore allo sfregamento a secco: scarica CO 4/5 (ISO 105-X12)

Solidità del colore allo sfregamento ad umido: scarica CO 4/5 (ISO 105-X12)

Solidità del colore alla luce: 3/4 (ISO 105 B02)

Composition 100%PL

Total width: 140 cm (UNI EN 1773)

Weight per linear meter: 460 g/LM (± 4%)

("Martindale") Abrasion resistance. Rubs: 30.000 End point (ISO 12947-2)

Pilling resistance: 4/5 (ISO 12945-2)

Tensile strength: Length 1000 - Width 1300 (ISO 13934-1)

Seam slippage at less than 6 mm: Length >200 - Width >200 (ISO 13936-1)

Colour fastness rubbing (dry): staining CO 4/5 (ISO 105-X12)

Colour fastness rubbing (wet): staining CO 4/5 (ISO 105-X12)

Colour fastness artificial light: 3/4 (ISO 105 B02)



IRRESTRINGIBILE
NO-SHRINK

IDROREPELENTE
WATER-REPELLENT



BY100



BY400



BY401

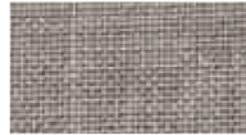

BY605

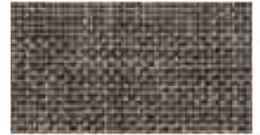

BY600



BY402

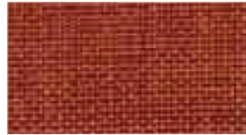

BY307

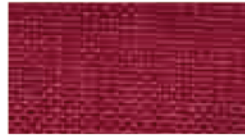

BY303

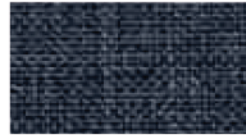

BY707

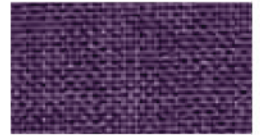

BY003



BY804



BY700



BY403



BY405



BY602

KIRKBY DESIGN

Basket

Larghezza: 136 cm (53 1/2")

Ripetizione: [12,5 cm (5") → 11,5 cm (4 1/2")

Composizione: 100% PL

Point

Larghezza: 136 cm (53 1/2")

Ripetizione: [10,5 cm (4 1/4") → 19,5 cm (7 3/4")

Composizione: 100% PL

Brick

Larghezza: 136 cm (53 1/2")

Ripetizione: [31,5 cm (12 1/2") → 17 cm (6 3/4")

Composizione: 100% PL

Terrazzo

Larghezza: 136 cm (53 1/2")

Ripetizione: [21 cm (8 1/4") HD → 54 cm (21 1/4")

Composizione: 100% PL

Basket

Width: 136 cm (53 1/2")

Repeat: [12,5 cm (5") → 11,5 cm (4 1/2")

Composition: 100% PL

Point

Width: 136 cm (53 1/2")

Repeat: [10,5 cm (4 1/4") → 19,5 cm (7 3/4")

Composition: 100% PL

Brick

Width: 136 cm (53 1/2")

Repeat: [31,5 cm (12 1/2") → 17 cm (6 3/4")

Composition: 100% PL

Terrazzo

Width: 136 cm (53 1/2")

Repeat: [21 cm (8 1/4") HD → 54 cm (21 1/4")

Composition: 100% PL



Iron on reverse



K5128_04



K5128_09



K5128_10



K5128_12



K5129_01



K5129_02



K5129_03



K5129_11



K5130_03



K5130_06



K5130_10



K5130_11



K5130_13

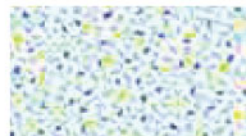

K5131_01

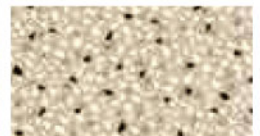

K5131_09

ROMO

ALLUMINIO - Aluminium



AL01

Alluminio verniciato
goffrato bianco
White embossed
painted aluminium



AL02

Alluminio verniciato
goffrato sabbia
Embossed sand
painted aluminium



AL03

Alluminio verniciato
goffrato antracite
Embossed anthracite
painted aluminium

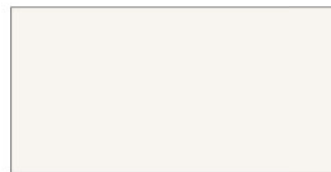

AL04

Alluminio verniciato
bianco lucido
Polished white
painted aluminium



AL05

Alluminio verniciato
nero lucido
Polished black
painted aluminium



AL06

Alluminio anodizzato
Anodised aluminium



AL07

Alluminio pulito
Polished aluminium



AL08

Alluminio verniciato rosso
Red painted aluminium



AL09

Alluminio verniciato
goffrato nero
Embossed black
painted aluminium



AL10

Alluminio verniciato
goffrato grigio
Embossed grey
painted aluminium

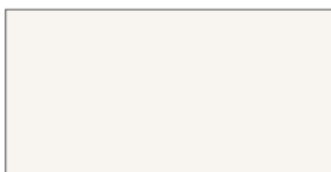

AC30

Alluminio verniciato
bianco opaco
White matt
painted aluminium



AC31

Alluminio verniciato
nero opaco
Black matt
painted aluminium



AC32

Alluminio verniciato
grigio opaco
Grey matt painted
aluminium

ACCIAIO - Steel - Acero



AC01
Cromato
Chromium-plated



AC11
Acciaio verniciato
goffrato antracite
Embossed anthracite
painted steel



AC12
Acciaio cromato nero
Black chrome steel



AC13
Acciaio cromato rame
Copper chromed steel



AC03
Acciaio verniciato
nero goffrato
Black embossed painted
steel

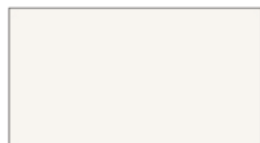

AC20
Acciaio verniciato
goffrato bianco
White embossed
painted steel

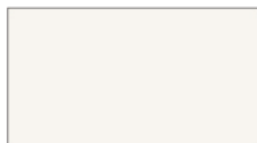

AC30
Acciaio verniciato
bianco opaco
White matt painted steel



AC31
Acciaio verniciato
nero opaco
Black matt painted steel



AC32
Acciaio verniciato
grigio opaco
Grey matt painted steel



AC33
Acciaio verniciato
sabbia opaco
Sand matt painted steel

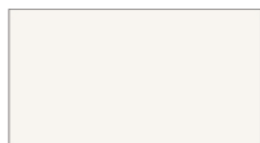

AC101
Acciaio verniciato
bianco lucido
Polished white painted steel



AC102
Acciaio verniciato
nero lucido
Polished black painted steel



AC103
Acciaio verniciato
grigio lucido
Polished grey painted steel



AC514
Acciaio verniciato
goffrato sabbia
Embossed sand
painted steel



AC1016
Acciaio verniciato
goffrato giallo
Embossed yellow
painted steel



AC3020
Acciaio verniciato
goffrato rosso
Embossed red painted steel



ACG02
Acciaio verniciato
grigio medio
Medium grey painted steel

ROVERE HERITAGE



RH03
Rovere heritage naturale
Heritage natural oak

MICROTOPPING

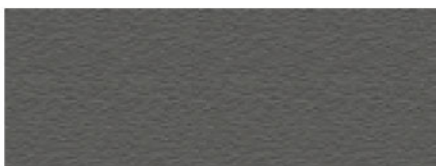

MT06
Microtopping antracite
Anthracite microtopping

NEWPANN



NEW01
Rovere grigio
Grey oak



NEW02
Rovere sbiancato
Whitened oak

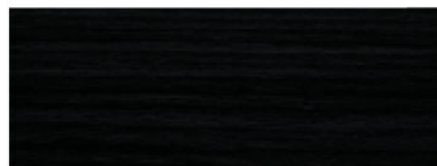

NEW03
Rovere verniciato nero
Painted black oak



NEW04
Verniciato bianco goffrato
Embossed white painted



NEW05
Verniciato antracite goffrato
Embossed anthracite painted



NEW06
Verniciato nero goffrato
Embossed black painted

VETRO - Glass

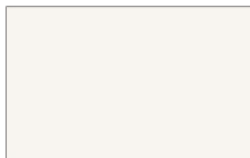

VE01
Satinato bianco
Satin-finish white



VE02
Satinato antracite
Satin-finish anthracite



VE03
Satinato sabbia
Satin-finish sand

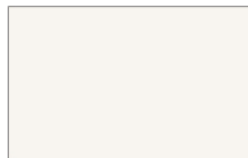

VE04
Bianco
White



VE05
Nero
Black



VE07
Verde acidato
Frosted green



VE08
Cristallo trasparente
Clear glass



VE09
Satinato nero
Satin-finish black

SIMBOLOGIA - SYMBOLS



Ignifugo.
Fireproof.



Lavare a mano alla temperatura massima indicata.
Hand wash at max temperature indicated.



Non lavare.
Do not wash.



Non candeggiare.
Do not bleach.



Lavare a secco con i solventi abituali, a base di percloroetilene, di solvente R113 e di idrocarbonio (ma senza tricloroetilene).
Dry clean with usual solvents, based on perchloroethylene, solvent R113 and hydrocarbon (no trichloroethylene).



Stirare con il ferro da stiro. I punti al centro del simbolo indicano la temperatura:
Un punto Stirare a ferro freddo (110°): acrilico, nylon, acetato.
Due punti Stirare a ferro caldo (150°): poliestere, lana.
Tre punti Stirare a ferro molto caldo (200°): cotone, lino.
Iron. The dots in the centre of the symbol indicate the temperature:
One dot: iron cold (110°): acrylic, nylon, acetate.
Two dots: iron warm (150°): polyester, wool.
Three dots: iron hot (200°): cotton, linen.



Non utilizzare l'asciugatrice.
Do not tumble dry.